



MANTAFOILS

USER MANUAL





Warranty

The product is subject to a warranty that is limited to a period of 12 months from the shipping date of the related product order. For full details about the warranty, please visit <https://www.mantafoils.com/tofs>





| | |
|--|----|
| Safety Warnings and Disclaimers | 1 |
| VOLT 2 efoil – what’s in the box | |
| package 1 - volt 2 efoil | 2 |
| Package 2 - boards | 9 |
| Package 3 – battery | 11 |
| Package 4 – charger | 12 |
| Prior to the ride | |
| Board Assembly | 13 |
| Attaching the foil to the board | 15 |
| Assembly of wing to the E-foil | 16 |
| Assembly of propeller and prop guard | 17 |
| Charging | 21 |
| Installing the battery | 23 |
| Ready to ride | |
| Resting and Carrying your Board | 24 |
| Getting onto your board | 25 |
| Riding your board | 27 |
| Post ride | |
| Getting back to the shore and powering off | 29 |
| Post ride cleaning | |
| Maintenance and storage | 30 |
| Mantafoils Mobile Application | |
| Downloading the app | 31 |
| App - Logs Access | 32 |
| App - Battery Status | 33 |
| App - Firmware Update | 35 |
| App - User Guides | 37 |



WARNING

We understand your excitement to ride your new E-foil. However, read the following section carefully to ensure longevity of the product and safety of the rider. Failure to comply to these warnings may result in serious injury or death of the rider or other. Please fully read and comply with the user manual before use. If you are unsure how to operate the device, contact your dealer.

Use of the product and participation in the sport may lead to risk of injury or death. By using this product, the user accepts the inherent risk of use.

Note

The information contained in this User Manual contains the latest information available at the time of printing. Mantafoils is committed to continuous product improvements and reserves the right to modify the product, components, specifications or other aspects of the Mantafoils product without advance notice.

This manual is recorded to facilitate the user with all required information for the assembly and maintenance of the Mantafoil Volt 3 e-foil. For any further assistance on troubleshooting issues not included in this manual, kindly contact the mantafoil support team at support@mantafoils.com

WARNING

- HIGH VOLTAGE, DO NOT OPEN, NO SERVICABLE PARTS INSIDE. RISK OF ARC FLASH, ELECTRIC SHOCK, SERIOUS INJURY, DEATH.**
- RISK OF ELECTRICAL SHOCK. DO NOT HANDLE WITH WET HANDS OR IN WATER. DO NOT CONNECT THE BATTERY IN WATER**
- RISK OF FIRE, STORE IN DRY PLACE. DO NOT EXPOSE TO DIRECT SUNLIGHT.**
- DO NOT EXPOSE HEAT SOURCE / TEMPERATURE ABOVE 45° C / 115° F. HIGH TEMPERATURE CAN LEAD TO FIRE OR EXPLOSION. DO NOT USE IN TEMPERATURE BELOW 0° C / 32° F.**
- RISK OF EXPLOSION. DO NOT DISPOSE THIS BATTERY. RECYCLING OF LI-ION BATTERY REQUIRES SPECIALIZED FACILITIES.**
- TRANSPORT THIS BATTERY PACK IN ACCORDANCE WITH ALL APPLICABLE LAWS. REFER TO BATTERY MSDS FOR FURTHER DETAILS**
- DO NOT LEAVE THE BATTERY UNATTENDED WHILE CHARGING. CHARGE IN DRY AND SAFE ENVIRONMENT. ONLY CHARGE WITH THE SUPPLIED DEDICATED CHARGER.**
- DO NOT OPEN, OR ATTEMPT TO MODIFY THIS BATTERY. ONLY USE THIS BATTERY FOR ITS INTENDED PURPOSE.**
- DO NOT MISHANDLE, DROP, PUNCTURE, DAMAGE THIS BATTERY. CAREFULLY INSPECT THE BATTERY PRIOR TO EACH USE. IN CASE OF ANY DAMAGE, DO NOT USE THIS BATTERY.**

LI-ION BATTERY
 MODEL MF-VOLT-14S10P
 RATED CAPACITY: 50Ah / 2.6kWh
 INPUT VOLTAGE: 52V NOMINAL / 15A CONTINUOUS CHARGE CURRENT
 OUTPUT VOLTAGE: 52V NOMINAL / 80A CONTINUOUS DISCHARGE CURRENT / 120A PEAK (10s)
 POLARITY: ORANGE + / BLACK-
 IP RATING: IP67 (WITH CONNECTORS MATED ONLY)

FOR FURTHER INSTRUCTIONS REFER TO USER MANUAL



UNBOXING

The Volt 3 e-foil will arrive to you in 4 separate packages:

- E-foil Propulsion Unit
- E-foil Surfboard
- Battery
- Battery Charger

PACKAGE 1: E-foil Propulsion

E-foil propulsion unit

The E-foil propulsion unit package arrives in the E-foil travel bag along with the choice of wing(s), propeller, prop guard and accessories kit.

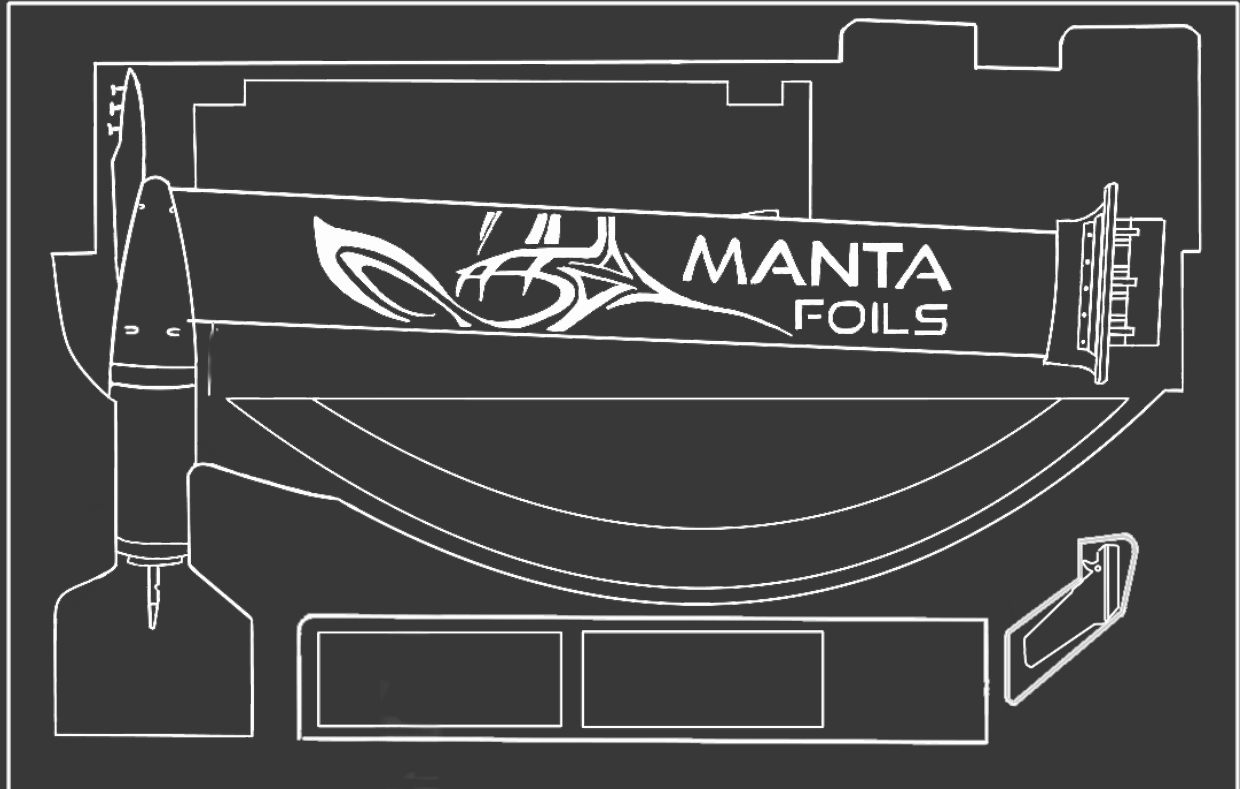



The Volt 3 e-foil propulsion unit is made available in two masts lengths

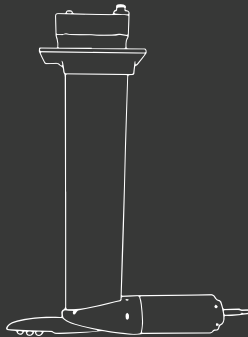

Volt 3 - 65cm

65cm long mast is for beginners and preferred for heavier riders.

Preferred for inflatable boards and suitable for most riders.

Adapted for riding in flat waters.

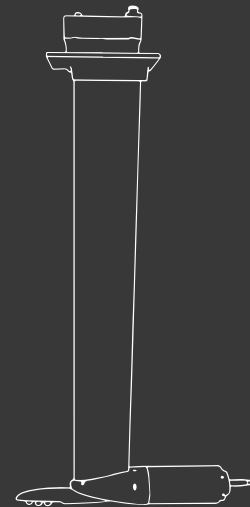

Volt 3 - 85cm

85cm long mast is for intermediate and advanced riders.

Suitable for carbon boards and allows riders to carve like nothing else.

The extra mast length also provides peace of mind when cruising at high speed or riding in choppy waters.



as well as four wing sizes

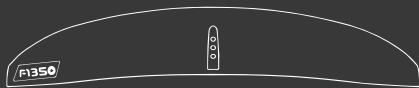

GLIDER WING 1350 cm2

The Glider 1350 cm2 high aspect e-foil wing will improve top speed and range and at the expense of lower lifting power. Not suitable for sharp turns carving.

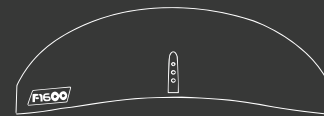

FREERIDE WING 1600 cm2

The Freeride 1600 cm2 e-foil wing is the standard choice for most riders. It enables stable low to medium speed flights and long range and turns smoothly. It will allow heavy riders to fly easily.

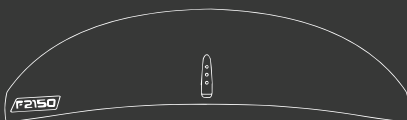

LIFTER WING 2150 cm2

The lifter 2150 cm2 e-foil wing is dedicated for heavy riders for which the freeride 1600 cm2 is not enough. It enables stable low speed flights and long range and turns smoothly.

It will also allow heaviest riders to fly easily.

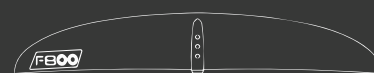

RACE WING 800 cm2

The Race 800 cm2 efoil wing is designed for riders seeking for higher speed and more aggressive carving capability.

It is recommended for advanced riders only.



along with the **PROPELLER AND PROP GUARD;**

The Innovative prop guard design has a built in stabilizer , Adjustable angle system, Water breaching capability and also reduces risk of injury from propeller and wing tips.

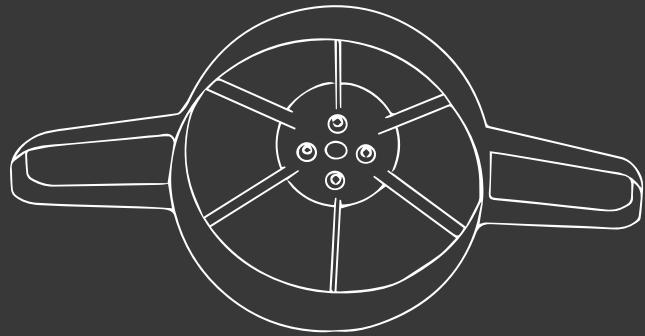
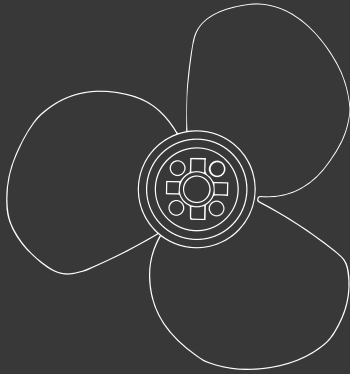



Remote Control



Wireless charging pad and cable



Tef Gel



Reelx Anticorrosion Gel

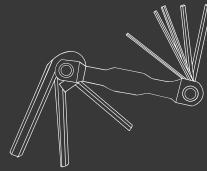

Hex key Set



Power Cable Set



Receiver Unit

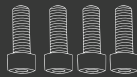

4 - M5 X 16 screws



2 - M8 X 25 screws



1 - M8 X 20 screws

Screw Set

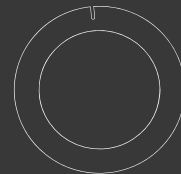

Spacers X 2

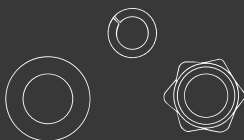

M8 nut
M5 washer x4
M8 washer x 5

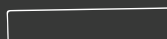

Propeller Pin

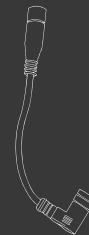

90 Angle Cable



Additionally, the following accessories are also included depending on the board type

For Inflatable Boards

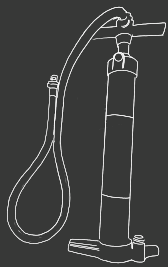

Air Pump

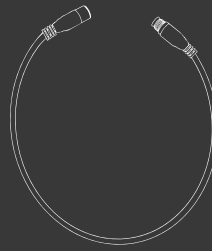

Data Extension Cable
10.5cm

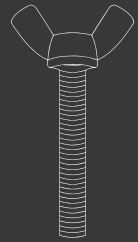

Butterfly Screw
45mm



M8 x 20



For Carbon Boards

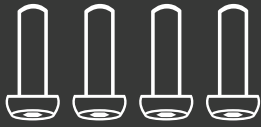

M8 x 35

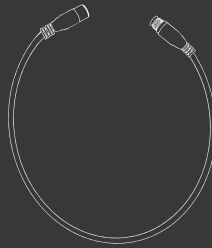

Data Extension Cable
170cm

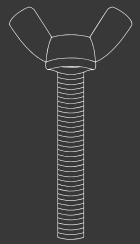

Butterfly Screw
50mm



PACKAGE 2: E-foil Surfboard

The E-foil Surfboard arrives in its own surfboard bag. The available board types are:

INFLATABLE

Easy to transport when deflated and folded in half. The inflatable robust material will prevent damages when handled on sensitive surfaces such as yacht decks. Additionally, the soft material reduces risk of injury.

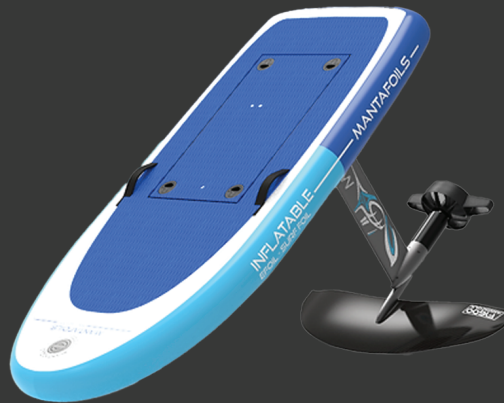

CARBON

The Carbon boards are low volume and light weight. They provide a more rigid base and allow for advance level manoeuverability.





The four available board sizes are

INFLATABLE

110 litres

The Inflatable 110L suits most riders. Easy to transport when deflated and folded in half.

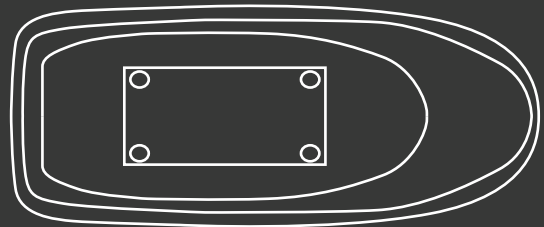

145 litres

The Inflatable 145L is similar to the Inflatable 110L with an additional 35L to suit heavier riders.

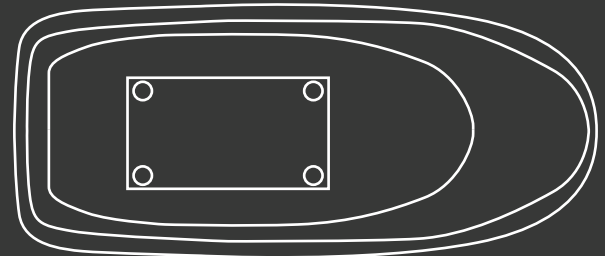

CARBON

95 litres

The Carbon 95L features high rigidity and medium volume for good all around performance.

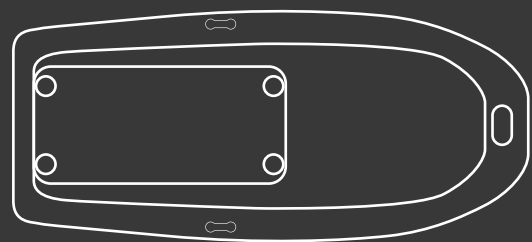

65 litres

The Carbon 65L board's low volume and size makes it the perfect toy for advanced riders. The narrow shape allows for high carving angles and high speed.

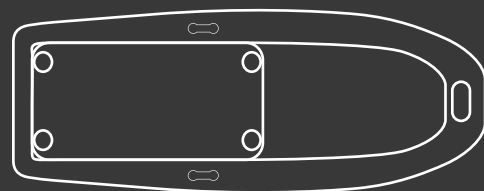



PACKAGE 3: Battery

The 50Ah - Long range smart battery

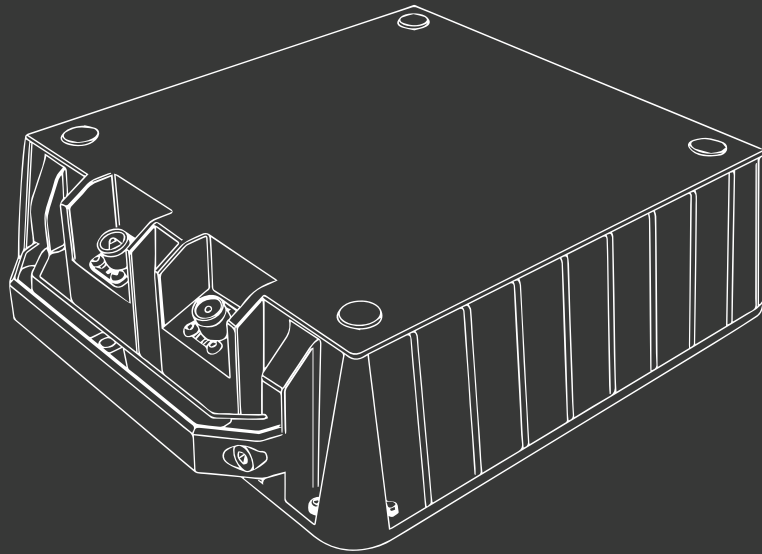

- Ride time up to 140min
- Fully waterproof (IP67)
- Bluetooth connectivity, battery status accessible via Mantafoils smartphone app
- Safety features such as short circuit protection, temperature and discharge monitoring



PACKAGE 4: Battery Charger

There are two types of battery chargers

STANDARD CHARGER

The standard charger is 15 Amps and require approximately 4.5 hours of charging

FAST CHARGER

The Fast Charger is 25Amps and require approximately 2 hours of charging.

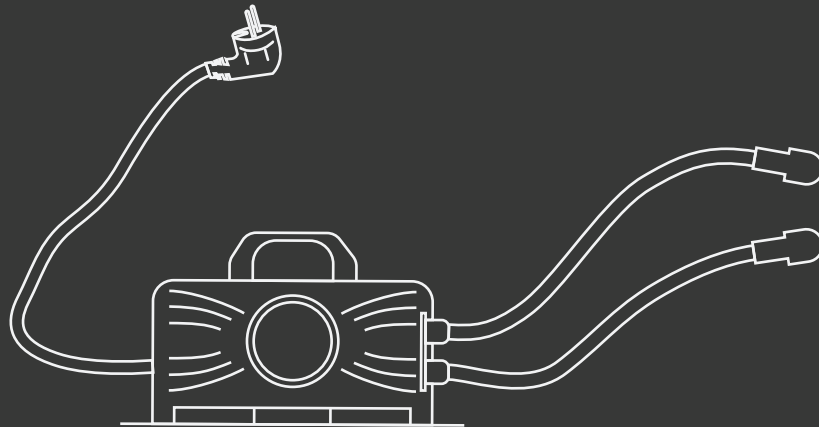



The Volt 3 E-foil has a simplified assembly process for the user. It is important to read through this section carefully and follow the assembly procedure listed below to prevent damage to any parts.

- Step 1 - Board Assembly.
- Step 2 - Attachment of foil to the board.
- Step 3 - Assembly of wing to the e-foil.
- Step 4 - Assembly of propeller and prop guard.

STEP 1: Board Assembly(Inflatable Board Only)

This section does not apply to carbon board users. Skip this section if you have a carbon board.

Inflating the board

Tools required: Air pump



Begin your assembly in a clean and flat area free of any sharp objects that could potentially dent or scratch your parts. For the Inflatable Board, remove the board from the board bag, unstrap the belt straps and lay it out with the battery compartment slot facing up.

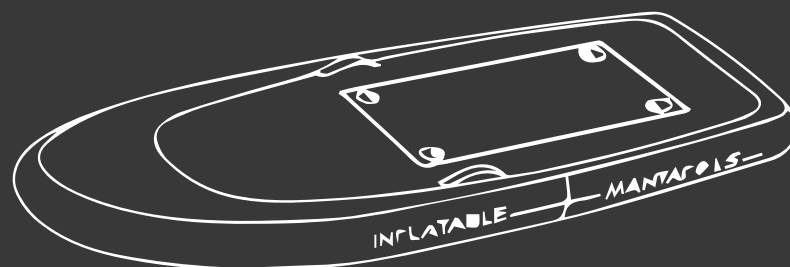



Begin by twisting the valve lock open located at the nose of the board. Rotate anti-clockwise until the valve pin pops out to lock air inside the board.

NOTE: If the valve pin is not outward, air will not be retained in the board while inflating.



Attach the pump hose into the valve and twist clockwise until it's locked into place and inflate the board to 15 PSI.

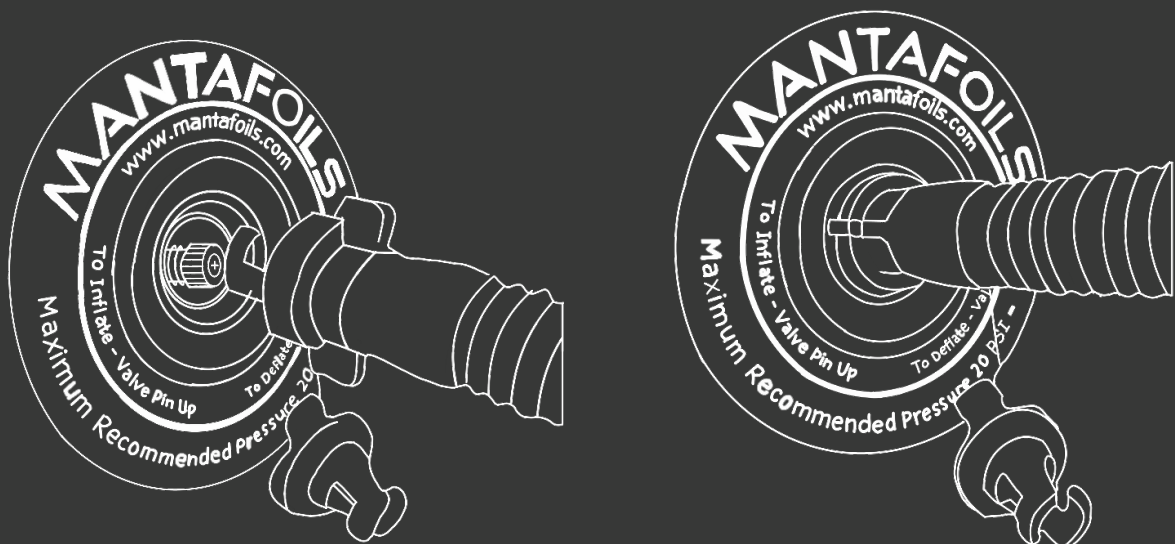

Once your board is fully inflated, detach the pump and close down the knob.
NOTE: If the board is stored inflated, it is normal for air pressure to reduce over the course of time.



3- Attachment of foil to the board

Tools Required: Hex Key Set, Tef Gel , 4 - M8 washers , 4- M8 Screws



Flip the board and place with battery compartment face down on the ground. The screws to attach the board and the foil come placed in their respective slots. The screw sizes for carbon boards are M8x35 and for inflatable are M8x20

Remove the screws on the board and place the seal on the foil head. Ensure the seal is in place.

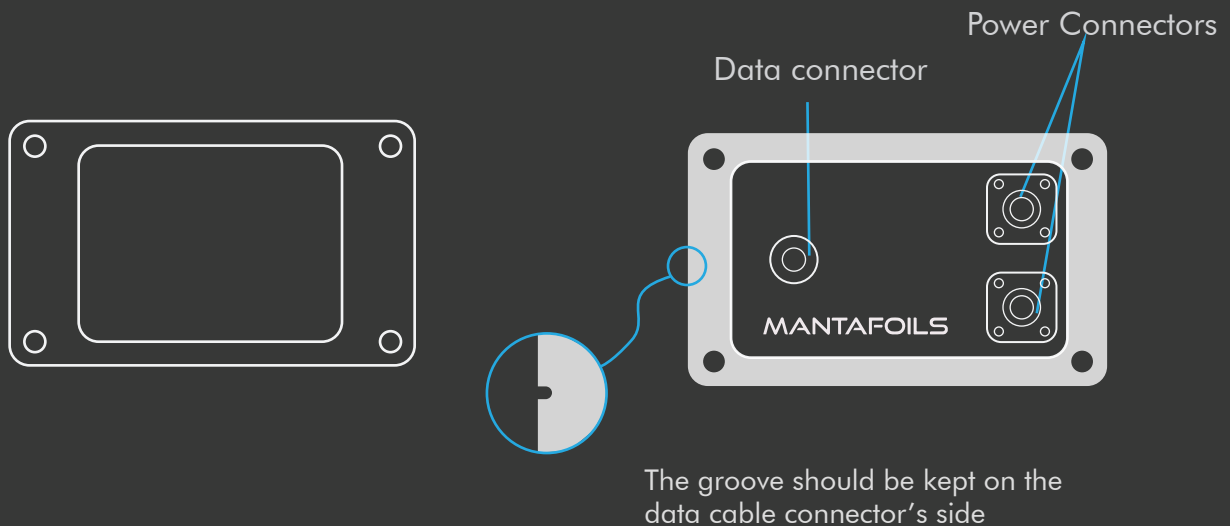

Apply Tef gel into the screw threads and screw down foil in place with the M8 washers provided using the hex tool set. The screws must be secured tightly.

NOTE: Always apply tef-gel to any screw inserts and for extended usage loosen the screws and reapply tef-gel every few weeks. This is to prevent corrosion of the aluminium surface in contact with the screws.

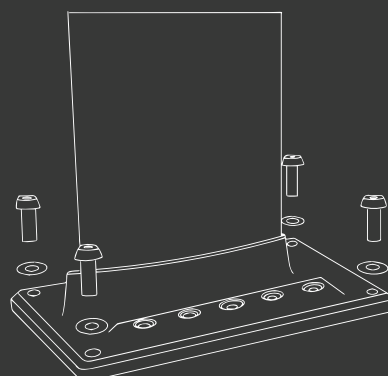



4- Assembly of wing to the e-foil

Tools Required: Hex Key, Tef Gel, 2 - M8 x 25 screws , 1 - M8 x 20 screws



Ensure the previous steps of assembly are completed before proceeding to this section. This will ensure easy installation and protection of your e-foil parts.

The screws to attach the wing to your fuselage also come positioned in their respective screw slots. When assembling the wing on the foil, the protruding spine of the wing should be the part in contact with the fuselage.

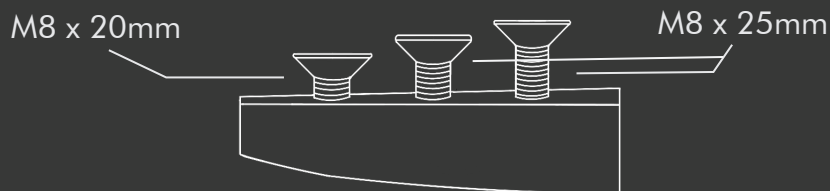

NOTE

Pay close attention to the placement of screws according to their respective sizes. The longer two screws must be towards the propeller and the shortest must be towards the nose of the fuselage.

Use allen key size of M8 from the provided tool kit and tighten the wing to the foil. The wing must not wobble on the foil and must sit sturdy in place.

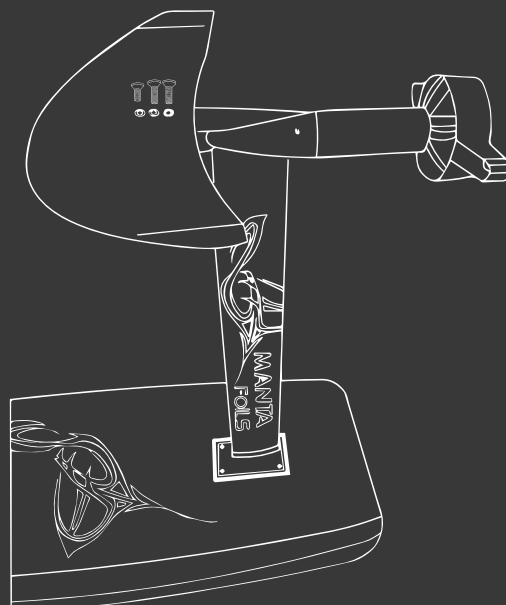



5- Assembly of propeller and prop guard

Tools Required: Hex Key, Spacers, M8 Bolt, M8 washer, M5 screws x4, M5 washers x4



This section is broken down into three subsections:

- 1.Placing the spacers on your motor.
- 2.Attachment of prop guard to your e-foil.
- 3.Attachment of propeller to your e-foil.

IMPORTANT: WHEN ASSEMBLING THE PROP GUARD AND PROPELLER ENSURE YOUR FOIL IS DISCONNECTED FROM THE MAIN BATTERY POWER TO PREVENT SERIOUS INJURIES

PLACEMENT OF SPACERS ON YOUR MOTOR

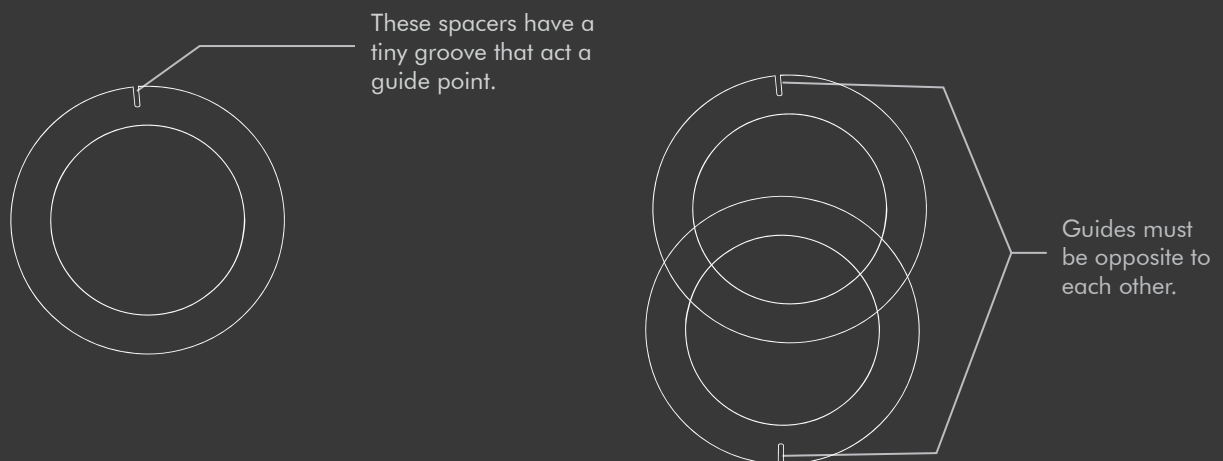

There are guide points on the spacers as shown in the figure above. Place both spacers flat on top of each other with guide points vertical and in the opposite direction of each other. Rotating the spacers in the opposite directions changes angle of the stabilizer wing and the pitching power of the e-foil.



2. Ensure the spacers are aligned together as one, place it flush on the motor head as shown in the figure. The spacer must be placed vertically with the guide points opposite to each other.

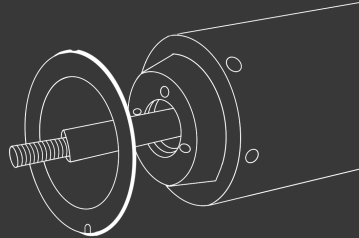

ATTACHMENT OF PROP GUARD ON YOUR E-FOIL

1. On the prop guard, there is an arrow that indicates the positioning on the efoil (refer to figure 3). After the spacer has been placed on the foil, place the prop guard with the arrow pointing upward in the same direction as the mast.

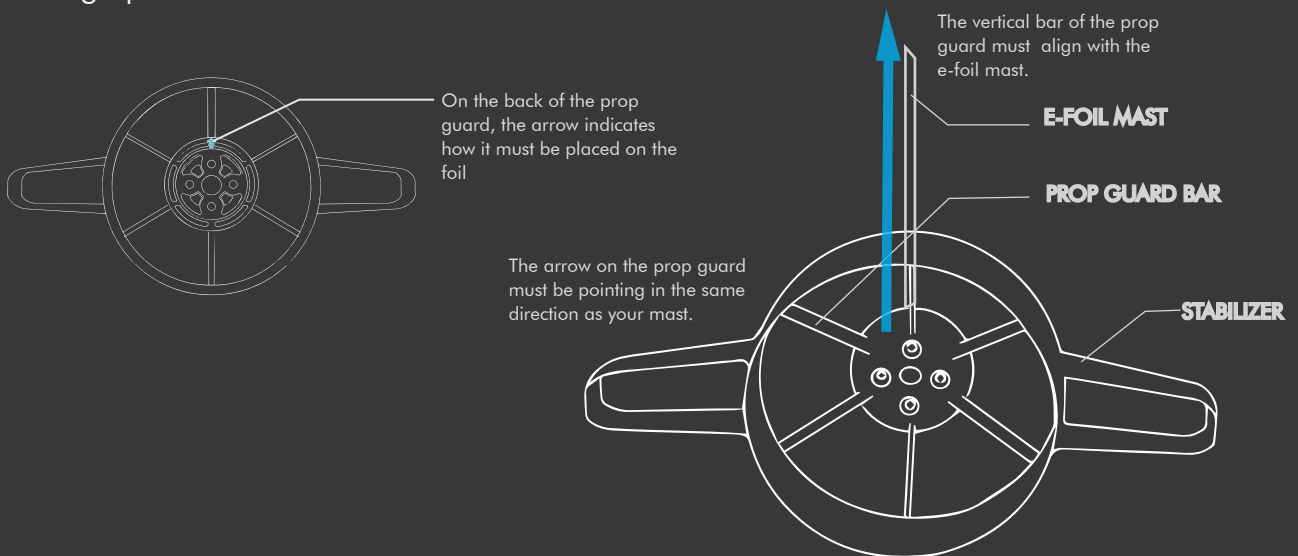

2. Align the prop guard as depicted in the figure below. Ensure the stabilizer is parallel to the floor and the bar of the prop guard aligns perfect vertically with the mast. Once the prop guard is aligned, screw it down with the screws provided.

Depending on your kit, you will be provided with the correct quantity of screws. If you have two screws, place them with the 5mm washers on opposite screw slots.

NOTE: It is crucial that the screws are secured tightly on the prop guard at all times to ensure long term use of your e-foil.



ATTACHMENT OF PROPELLER TO YOUR E-FOIL

IMPORTANT: The images in this section are merely to provide a clear view of the propeller assembly. **DO NOT** assemble the propeller without the prop guard at any instance on your foil

1. Place the propeller pin provided into the motor shaft and rotate the shaft so that the pin is horizontal to the floor. This position will help place the propeller with ease.

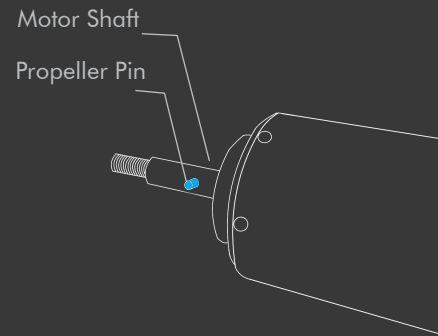

2. Behind the propeller, there are two pin slots to engage the propeller pin. If there is sufficient distance between the prop guard and the propeller pin, engage the propeller on the deeper pin slot. If there is insufficient distance, engage the propeller in the shallow pin slot.

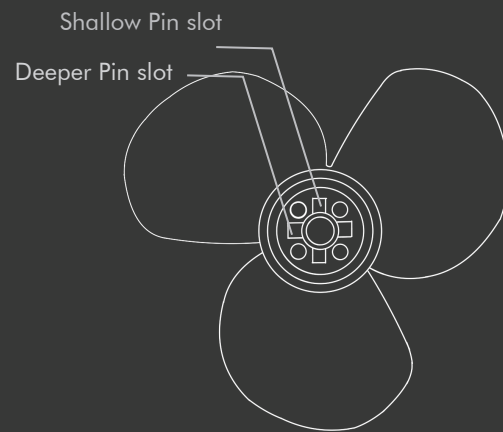

3. Place the propeller in alignment with the pin and push in place. The pin must be fully engaged with the propeller.

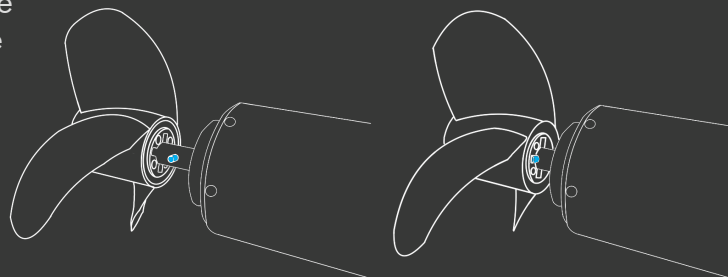

IMPORTANT: When placing the propeller to engage with the pin ensure the propeller slot aligns perfectly with the pin as once in place it may prove to be difficult to remove. If you do find yourself in the above situation, use a soft tool to remove the propeller from the motor shaft, realign the propeller and move into place again.



THE FINAL ASSEMBLY OF PROPELLER AND PROP GUARD

After instructions in Section I. and Section II. are followed, the final assembly of your e-foil will follow as below:

Once the prop guard is attached to the foil and the propeller is attached to the motor shaft with the pin engaged, place the washer first followed by the bolt. Lock the propeller in place using a 13mm hex nut socket wrench.

The base of the propeller must NOT touch the base of the prop guard. The indicator for correct assembly is if the propeller rotates along with the motor shaft freely and smoothly. This motion can be tested by hand. Ensure the foil is not powered on at any instance during the assembly.

IMPORTANT:

DO NOT assemble the propeller without the prop guard at any instance on your e-foil

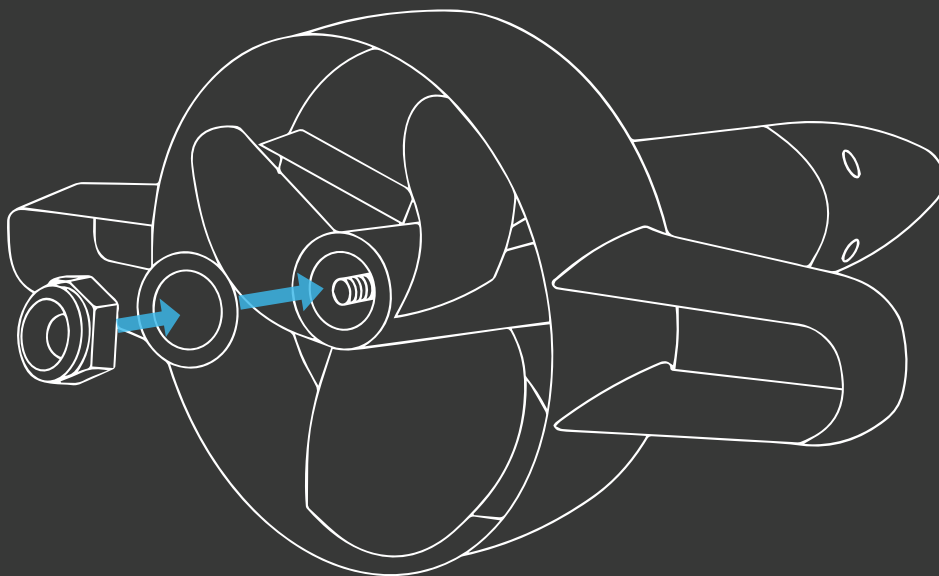



CHARGING

VOLT SMART BATTERY CHARGING

The Volt smart battery should ideally provide you with a ride time of 90-120 minutes depending on your weight and riding style.

- 1 - Position the charger in front of the battery near the connectors.
- 2 - Connect the charger connectors to the battery. The orange connector to the orange plug and black connector to black plug.
- 3 - Plug in the charger cable to the socket. The typical charge time is 4 hours on standard charger and 2 hours on the fast charger.

The battery status is accessible via the Mantafoils smartphone application.

CAUTION:

Do NOT keep charger unattended while charging. If the battery heats up while in charging, disconnect charger. Charging MUST be carried out in a dry and safe location.

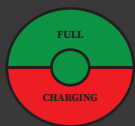

fully charged

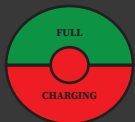

In charging

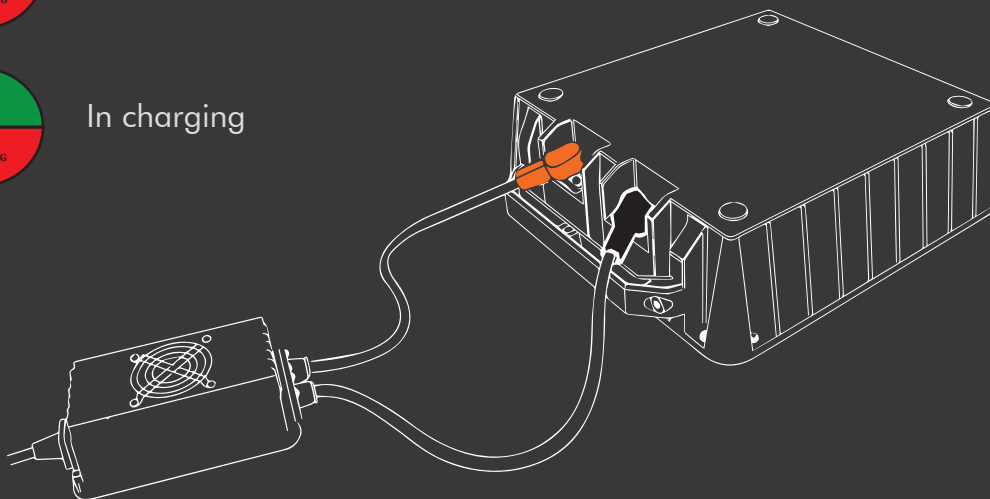

After charging or when not in use, it is recommended to keep the Volt Smart Battery stored in an optional fireproof case.



CHARGING

The battery charger has an LED status indicator. The indication description is listed below. The '-' indicates a second pause. The status should be read from the power ON state of the charger to the battery.

| Indicator State | Fault Indication | Solution |
|---------------------------|-------------------------------|---|
| Red Green | No power | The connection between charger and battery is not secure or battery voltage is too low. Recheck if connectors are plugged in correctly. |
| Red-Green-Red - - - | Over Voltage | Switch off main power and retry. If error still persists, contact sales@mantafoils.com |
| Red Green Red Green -- | Ambient temperature too high. | Check if battery is kept for charging in a cool and ventilated |
| Green Red ---- | Output Under Voltage | Ambient temperature is too high. Check if battery is kept for charging in a cool and ventilated |
| Red Green ---- | Output Under Voltage | Contact sales@mantafoils.com |
| Red Green Red Green - | Input AC abnormality | Contact Mantafoil Support team. |

If any issues persists, contact mantafoils support team at support@mantafoils.com.



INSTALLING THE BATTERY

The next step is installing the Volt smart battery. Hold the battery by the handle and carefully lower it into the board cavity, placing the battery in the slot with the connectors on the battery are facing upward. To ensure the battery is secure in position, the bottom of the battery must lock in place under the two washer clips within the slot.

Once the battery is in place, lock into position using the butterfly screw. Ensure the screw is tightly secure.

Next, use the power cables to connect the battery to the foil. The orange connector on the battery is connected to the orange connector on the foil and the black connector on the battery is connected to the black connector on the foil. There should be an audible click when the connectors lock into place.

Closing the battery compartment powers on the foil. Ensure that nothing is caught between the seal of the battery compartment and is closed properly.

CAUTION:

Be careful not to damage the seals of the battery connectors.

Do not ride the foil unless the battery is locked into place properly.

NOTE:

The board has been designed to have the battery compartment filling up with water to provide additional cooling to the battery. The water will drain out through the designed one way ball valves from the foil plate head while you ride.

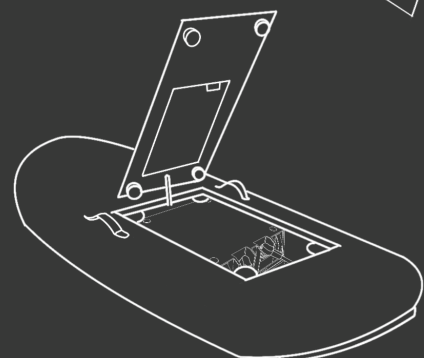
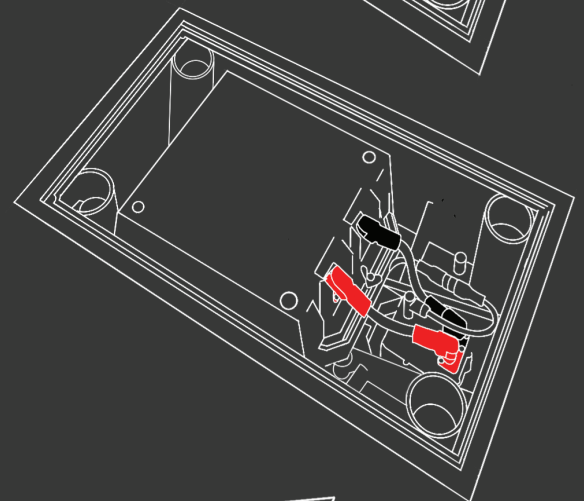
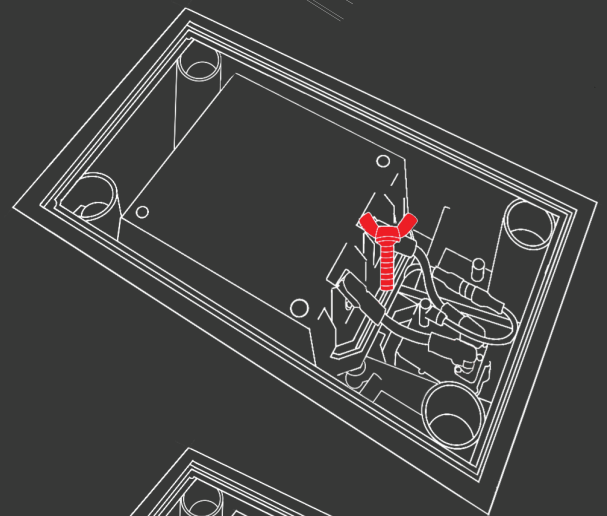
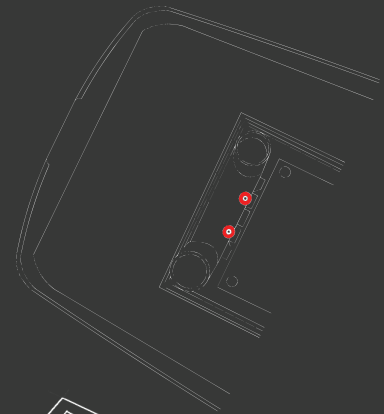



RESTING AND CARRYING YOUR BOARD TO THE SHORE

Before each ride, check that no screws are loose and the product is free of any damage. Also ensure that all the connecting cables are secured tightly. Should your product be damaged, contact your seller and refrain from using the product.

When you place your board on the shore, ensure that the nose of the surfboard is in contact with the sand and the propeller is facing upward. Alternatively, you may keep the board on its side. Pay attention to the wing tips while placing the board to prevent any damages.



After ensuring your board has been assembled and installed correctly with charged batteries, you are now ready to try out the board. The board can be tested with the remote controller outside the water.

NOTE: DO NOT RUN MOTOR FOR MORE THAN 5 SECONDS OUTSIDE THE WATER.

Carry the board to the water shallow enough to create a fair distance between the propeller and ground.

The board has side handles designed to carry it. Hold the board with one hand holding the handle and the second hand holding the mast. You may need to adjust your hand position on the mast to find the right balance.

CAUTION:

When lifting the board off the shore, pay particular attention to lift the wings completely to prevent the tip pressing on the ground and avoid wing breakage.



GETTING ON THE BOARD

Ensure that you are aware of your surroundings and others when in use of the product. Refrain from using the board in a crowded environment.

CAUTIONS:

Ensure that the wings and propeller never get into contact with the seabed as it could get trapped in the sand beneath or hit rocks and possibly damage the part.

Hold the remote in your dominant hand and tighten the remote band onto your wrist. Contact with the wings or propeller could lead to serious injury or death.

Do not turn on the remote when you or others are standing too close the propeller.

Do not step on the wing when climbing onto the board.

Wear tight swimwear and secure hair in place before you begin your ride.



When ready to go, climb onto the board staying on your chest and try to reach for the board's nose. Keep the elbows tucked to the side supporting your chest on the board and your feet on either ends at the bottom of the board.



Adjust your bodyweight toward the front of the board so that the board stays parallel to the water. In case the nose of the board lifts above the water, move yourself toward the front of the board. This will ensure better control and stability on the board. You are now ready to ride.

Note the position of the receiver only for inflatable boards is at the top front of the battery compartment. Since the board is designed to let water in, excessive weight on the board may lead to receiver immersion and loss of signal to the remote. Should this happen, you may either tilt the board a bit sideways to release water out. You may alternatively point the nose a bit upwards.



RIDING YOUR BOARD

1 - Gently and gradually press the trigger to increase the throttle of the motor.

When riding the first time do not try to go fast, just maintain slow speed to get used to the board dynamics and balance.

CAUTION:

Do not press trigger fully when you start out riding the e-foil especially while the throttle start mode is above 25% as it could lead to a board wipeout and lead to injury or death.

2- To navigate your board to the left or right, lean slightly towards your desired direction and the board will follow your movement. The more you are positioned back of the board the sharper the turn will be.

3- Once you are comfortable riding the board lying down, maintain constant speed to gradually move onto your knees whilst keeping the bodyweight on the front half of the board. Placing your hands on the board, push your body up and move your knees under you. Should you feel the foil lifting, move your body forward so that the board stays in contact with the water.

4 - Upon managing to control your throttle speed and body balance, you may slowly transition to your feet. Start putting your front feet forward while holding the board nose with your hand. Hold the trigger steady to avoid speed change while performing this body position transition.





5 - Always remember that weight pressure to the front of the board maintains it on the water. Only release front pressure when you are ready to fly. It is good practice for the rider to begin without flying at the very first ride and gradually attempt short flights while bouncing the board to the water.

6 - When the rider is familiar with the process, the rider can release the pressure at the nose of the board until it lifts off.

7- Moving body back pitch up the board, Moving forward pitch it down. Similarly throttling up pitch up the board while throttling down pitch down.

Note:

It is important to be smooth and precise with the trigger pressing and releasing. While learning you may hold the trigger fully and use the buttons to fine tune your speed.

8 - Practice makes perfect. Take your time out to get comfortable using the board and navigating it and maintain your throttle speed.

9- When starting out, wipeouts are normal and contribute to your learning process.

NOTE:

When you fall off the board, always immediately fully release the throttle trigger. This will automatically lock your remote.

10. Your weight plays a critical role to maintain balance on the board. Learn to adjust your weight on the board. Try to always maintain the board parallel to the water. If the nose of the board projects upwards you will topple off the board.

CAUTION:

When falling, Always try to fall away from the foil. Learning how to fall is an important part of the process and is key to reduce risk of injury or death.





POST RIDE

GETTING BACK TO THE SHORE AND POWERING OFF

- 1 - When you have finished riding your board, ensure to power the remote controller off by holding down the middle menu button for 5 seconds.
- 2 - Safely carry the board back to shore. You may carry the board from the handle and mast similarly to the technique used to carry the board to the water.
- 3 - Once on the shore, open the battery compartment. This will disengage the magnet and power off the foil.
- 4 - Detach the battery from the board by unscrewing the butterfly key from the lock. Disconnect the power connectors from the battery and replace the red caps back on the battery connectors to protect them and separate the battery from the board.
- 5 - Should you need to disconnect the foil from board, disconnect the long data extension cable from the 90 angle cable at the connection joint indicated in the figure below. Do not disconnect the 90 angle from the foil head. This connector shall be connected to the head at all time.

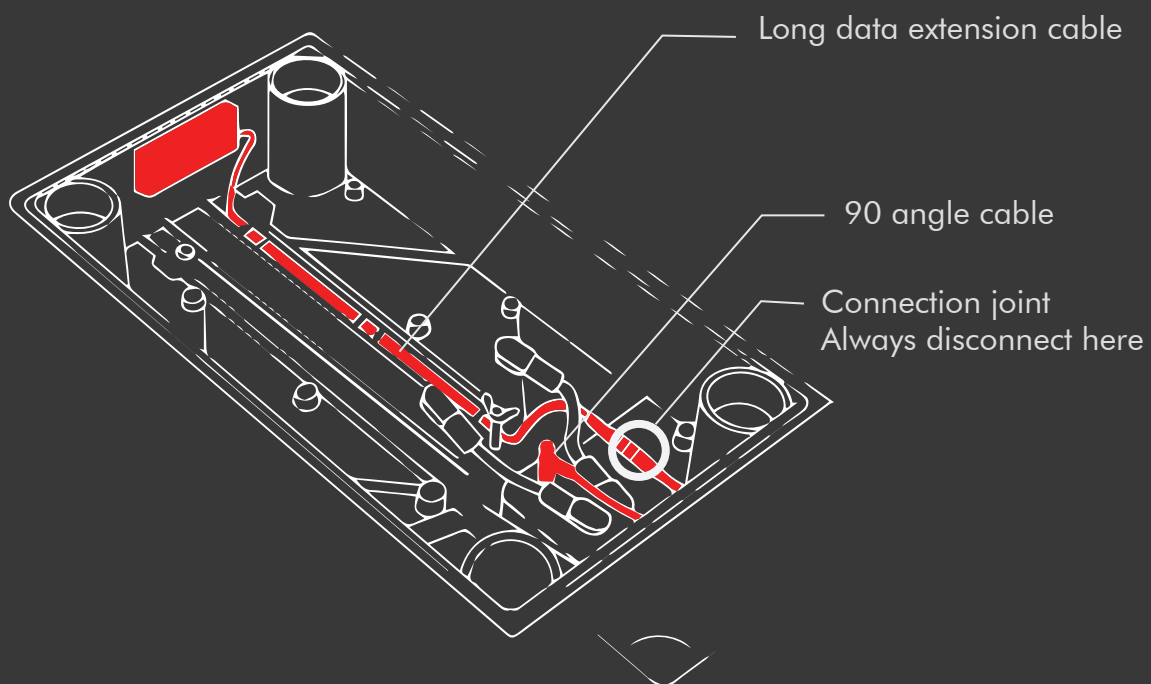



POST RIDE CLEANING

Ensure the following steps are repeated after each use and as needed to enjoy your future rides.

1 - When you are done using the e-foil board, spray down the board with pressurized fresh water to clean the board of any sand residue and salt water.

2 - Check to see if any debris has invaded the battery compartment or connectors. Rinse it out and dry with a towel.

NOTE:

Ensure the connectors and battery compartment is dried completely before being stored away.

3 - Rotate the propeller carefully by hand and rinse off excess sand residue.

4 - Wipe down the board and its accompanied parts clean with a dry towel.

MAINTENANCE AND STORAGE

1 - The e-foil and Battery **MUST** be stored in a cool and dry place. An exceeded duration of exposure to UV rays may lead to damages on the board and parts in addition to risk of fire. Additionally you may store the battery into purpose made fire retardant aluminum cases for enhanced safety.

2 - For increased longevity of your board, every few weeks reapply tef-gel to the fuselage and wings screw slots.

3 - Apply ReelX liquid to the connectors on regular basis (once every 15 rides)



Download the Mantafoil application from Google play store or Apple store on your device. The QR links are included below.



The official Mantafoils app



Download



Download



Once the logs access is enabled, open the Mantafoils application and click on the ride logs icon.

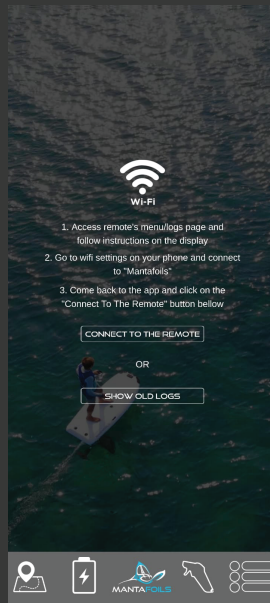

Connect to the Mantafoils wifi network and click 'connect to remote'. To view your ride logs click 'show old logs'.

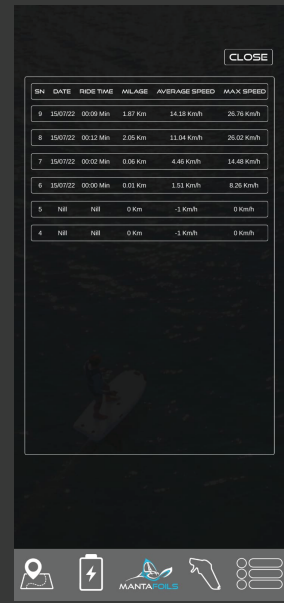

All the ride logs will appear listed. Click on any of the log files to view details of the ride.

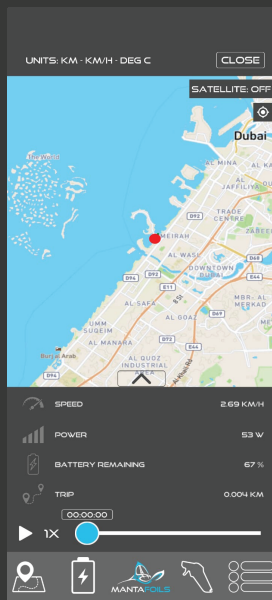

On this page, the ride can be replayed and view other data like the remaining battery percentage, the kilometers travelled and so on.

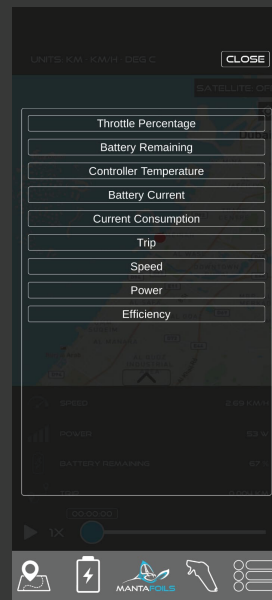

Clicking on any of the data presented will open an expanded window view of all the available ride information.



The Volt Smart Battery status can be monitored on the application. Ensure the bluetooth and location is enabled on your smartphone. The serial number of your battery is found on the bottom right conner.



Click on the battery icon.



Click scan to scan and connect to your battery.

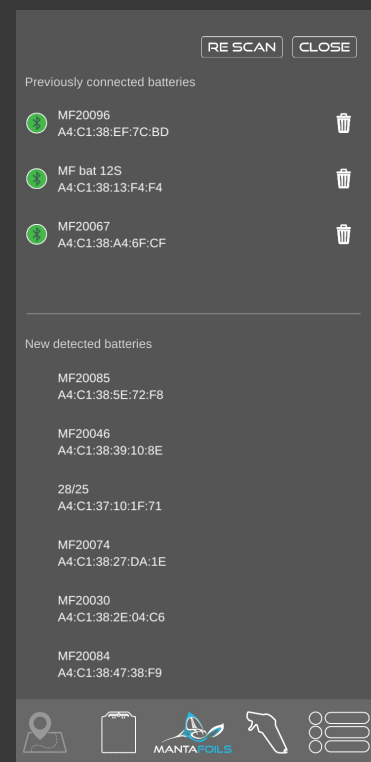

Within few seconds, the Battery should appear. Under 'new detected devices'. Click on the serial number of your battery to connect.

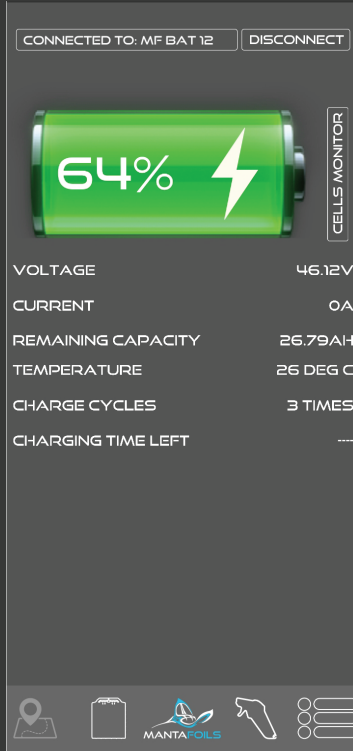

Once battery is connected, the battery charge percent is visible along with other battery parameters. Swipe right to monitor battery cells

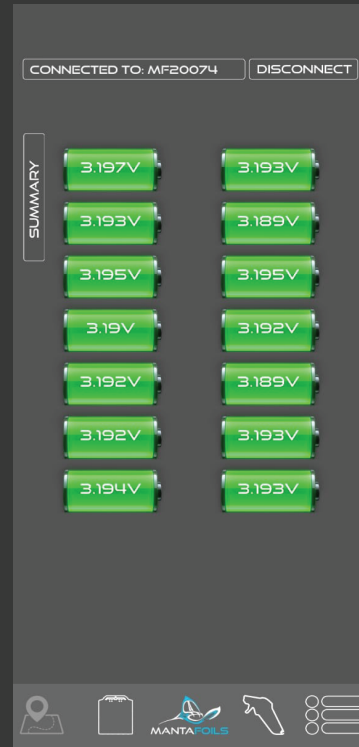

The battery cells are displayed on this page. the cumulative value is the present total voltage of the battery.

A validating check on your battery would be to ensure the cell voltages must be in the same range of values. if any individual(s) cell is lower, discontinue use of battery and contact sales@mantafoils.com



From the settings page, navigate to the firmware update page by pressing the '+' button.

- Make sure the remote is paired to your e-foil. (For this, read the instructions on pairing your remote with the board)



Click on the Remote Control Icon



Click on the latest firmware version

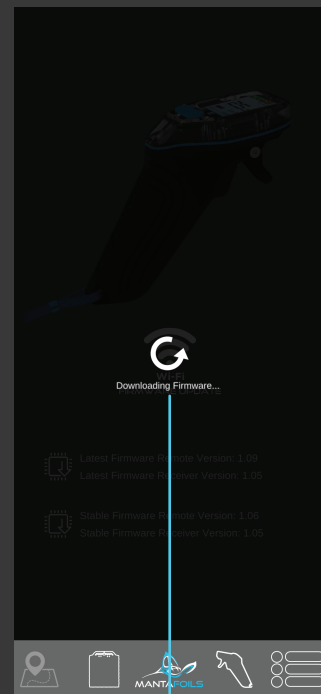

Wait for the download to finish



After the firmware update is downloaded on your mobile application, navigate to the firmware update page by pressing the '+' button seven times from the sub menu page.

- Press the 'O' button on the remote to activate the MantaFoil wifi network.
- Your remote will read 'Foil connected' and you will be prompted to connect your phone.
- Connect your phone to the MantaFoil wifi network.
- Click on the 'UPDATE' button on the application to install the update.

Wifi username: MANTAFOIL
Wifi password: Manta135

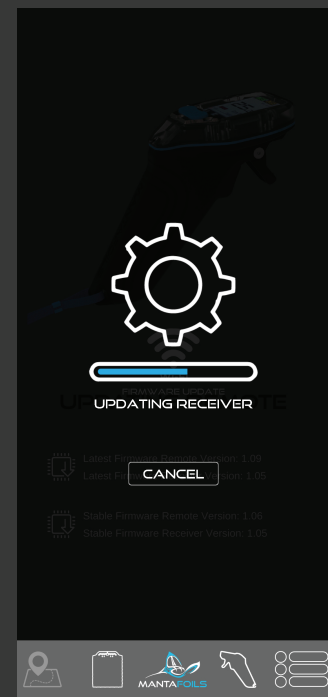
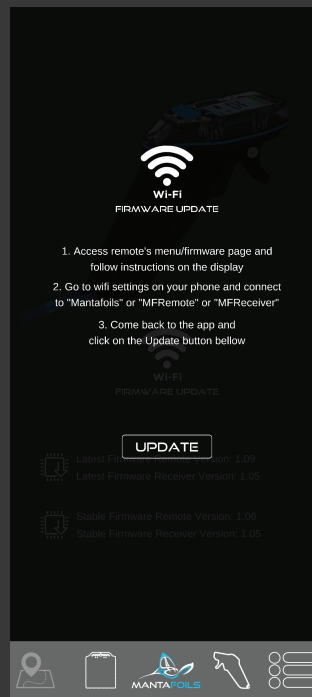
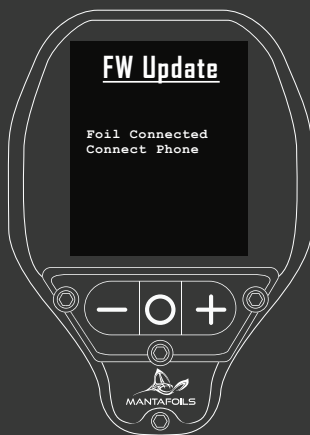

Once the installation is complete, your remote will read 'Lost Connection' and will automatically restart. This indicates that the update is successfully completed.

You can also verify the update by checking the Firmware Version shown on the start up page when the remote is powered on.



Click on the list icon to access the Mantafoil Volt 3 user manuals, tutorial guides and contact information for queries or support.

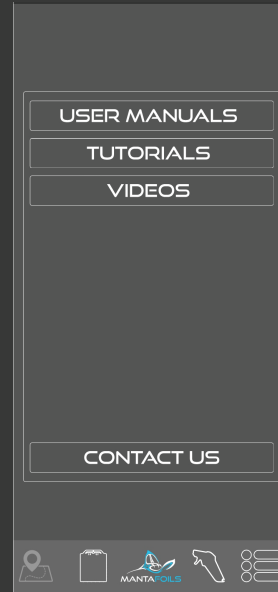

Click on the list icon to access the Mantafoil Volt 3 user manuals, tutorial guides and contact information for queries or support.



MANTAFOILS

VOLT 2 REMOTE
USER MANUAL

Warranty

The product is subject to a warranty that is limited to a period of 12 months from the shipping date of the related product order. For full details about the warranty, please visit <https://www.mantafoils.com/tofs>

| | |
|-----------------------------|----|
| Getting to know your remote | |
| Features | 1 |
| Unlocking the remote | 2 |
| Homescreen | 3 |
| Second Page | 4 |
| Third Page | 5 |
| Settings Page | 6 |
| Connecting to your Efoil | 7 |
| Trigger Calibration | 9 |
| Setting the Power Limit | 10 |
| Setting the Units | 11 |
| Metric Settings | 12 |
| Navigation | 13 |
| Customizing Display Cell | 14 |
| Display Color Settings | 16 |
| Throttle Start Setting | 17 |
| Throttle Ramp Setting | 18 |
| Downloading Firmware Update | 19 |
| Installing Firmware Update | 20 |
| Resetting your remote | 21 |
| Logs Access | 22 |
| Charging your Remote | 24 |
| Hardware Reset | 25 |
| Troubleshooting | 26 |

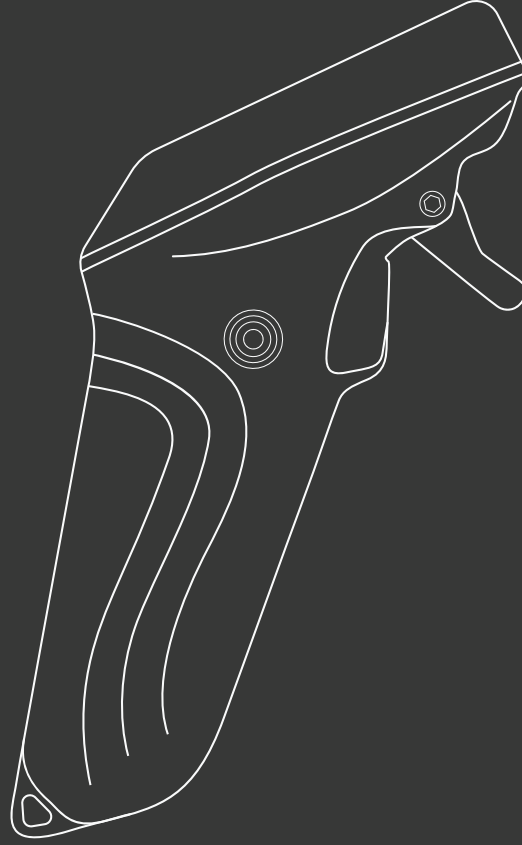

Configurable Display



Waterproof



Sunlight Readable



GPS Positioning Technology



Safety Lock



Cruise Control



Ride Logging



Wireless Charging



To begin using the remote, unlock the safety lock by pressing the '-' button once. the five second timeout will appear. Press the trigger before the countdown ends to start your ride.

Note:

This safety lock feature is in place to lock the trigger to prevent any accidental E-foil activation.

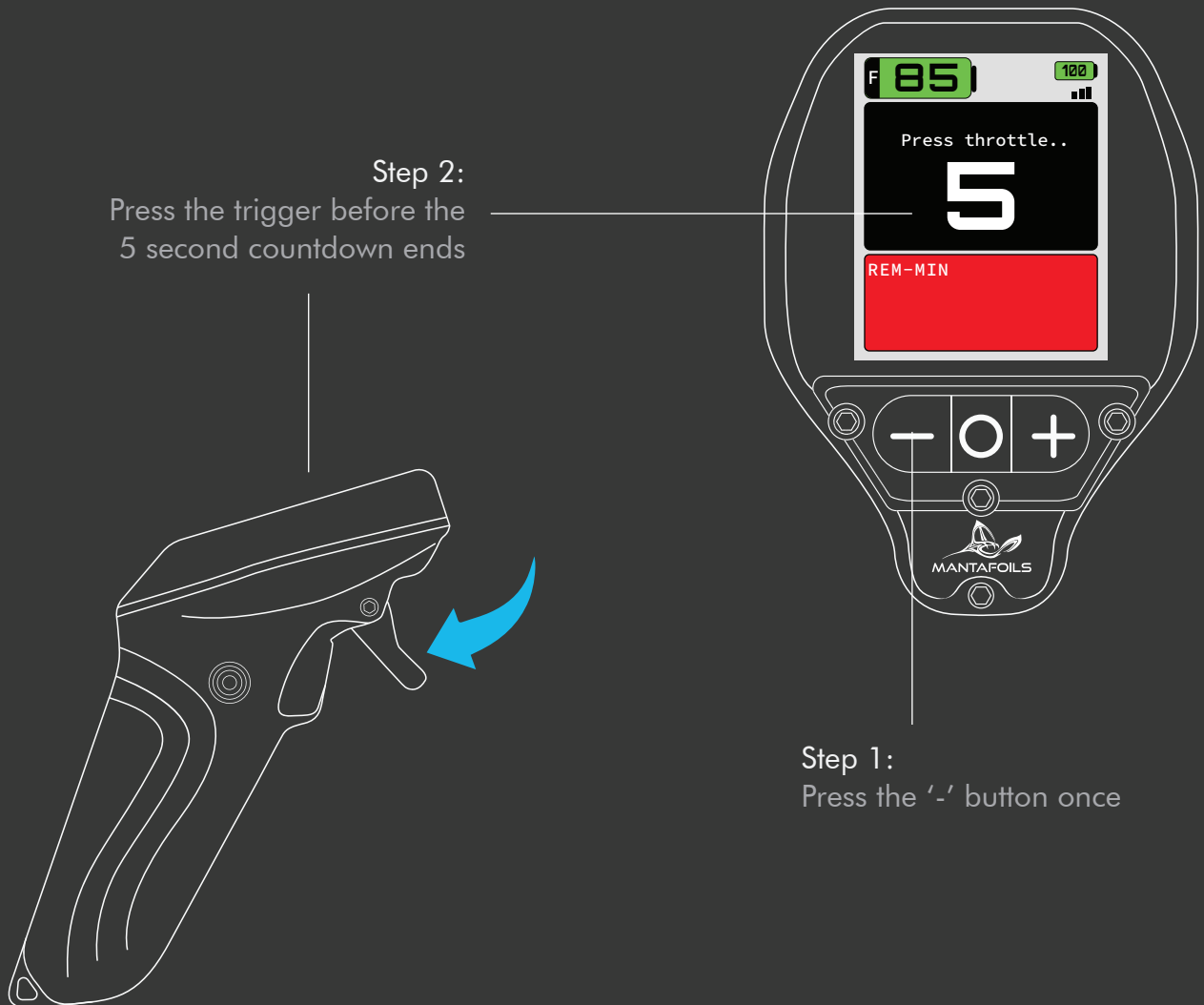



Power ON the remote by long pressing the 'O' button. When remote is powered ON, the homescreen will display the following:

1. The voltage of your E-foil
2. The GPS
3. The Remote Battery Voltage
4. Maximum power output. The Default is set to 25.
5. Remaining minutes. This indicates the remaining minutes of your ride time.

The remote needs to be paired to your e-foil to begin use.

Remote when powered on the first time.

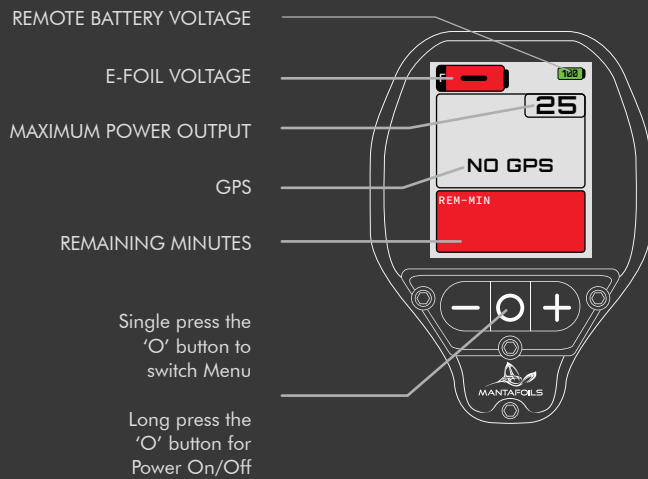

Remote after pairing to your e-foil. Follow the instructions under 'Connecting to the E-foil' section to pair your remote.

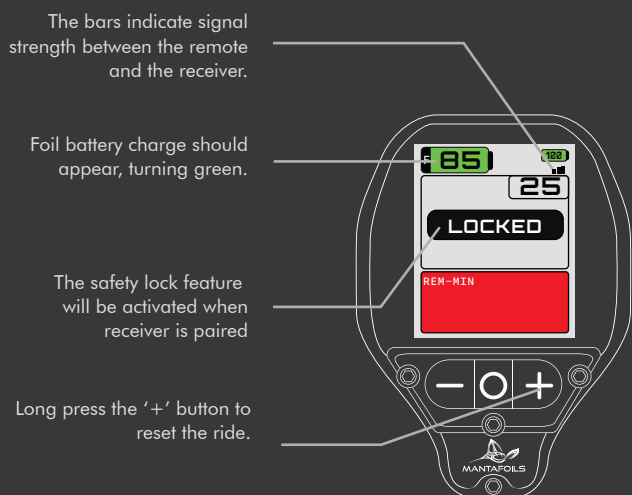



During your ride, your homescreen will displays the following information

1. The signal strength between remote and receiver
2. The E-foil battery percentage
3. The Remote Battery percentage
4. Maximum power output. TheDefault is set to 25.
5. Remaining Minutes
6. The cruising speed

On this page, use the '+' button to increase your cruise speed. Use the '-' button to decrease your cruise speed. Use the 'O' button to scroll through the first, second and third page.

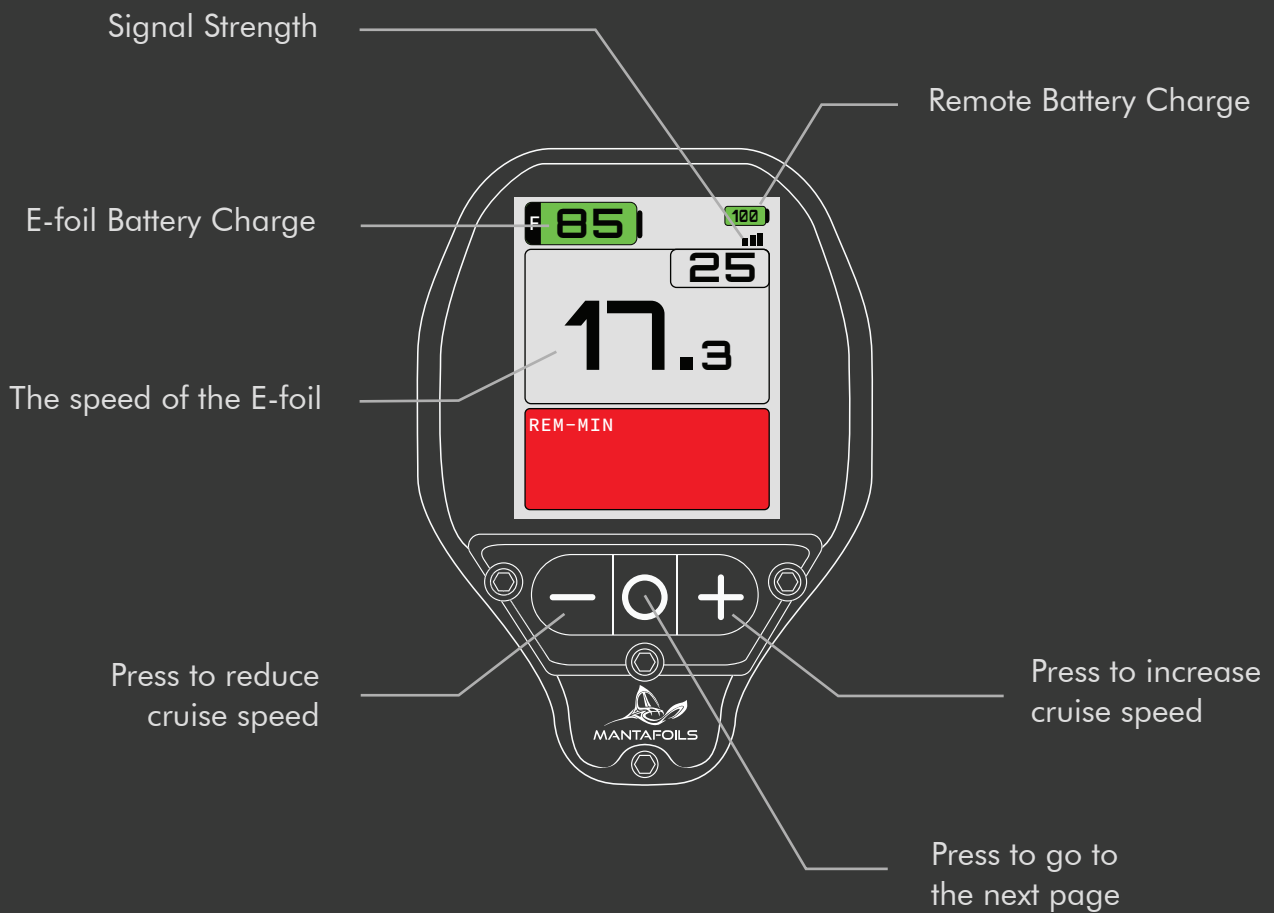



The second page records:

1. Elapsed minutes: The time covered since the start of your ride.
2. Elapsed Kilometers: The kilometers covered since the start of your ride
3. Remaning Minutes: Time remaining for your ride depending on the battery charge.
4. Remaining Kilometers: Kilometers remaining for your ride depending on the battery charge.

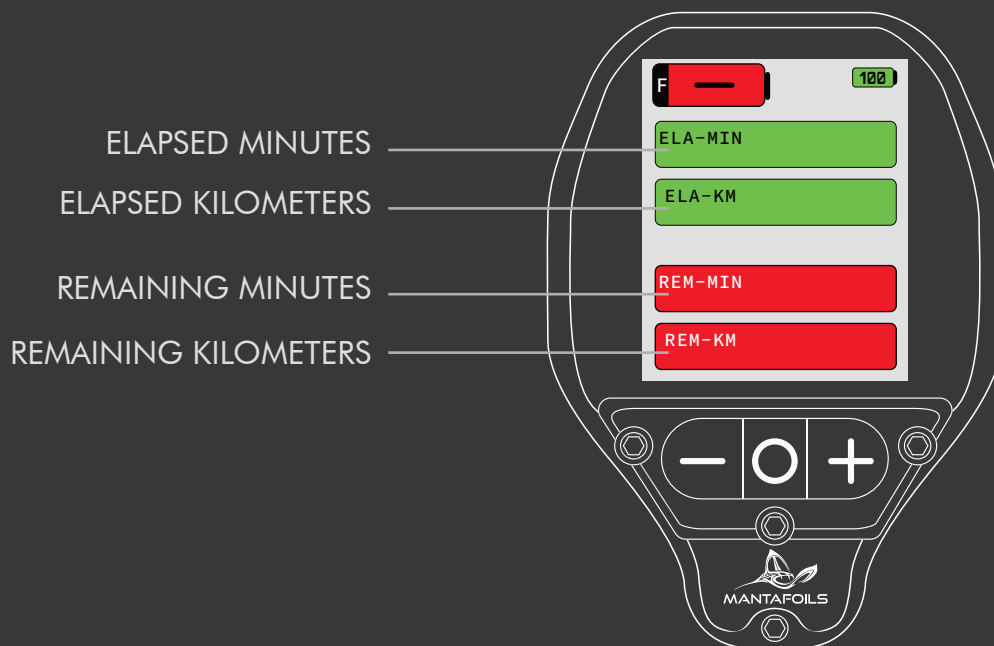



The third page records:

1. E-Foil Power: The wattage power of the e-foil.
2. Efficiency: The peak level of your foil performance in real time
3. Battery current: The battery current of the e-foil.
4. E-Foil temperature: The temperature of the e-foil

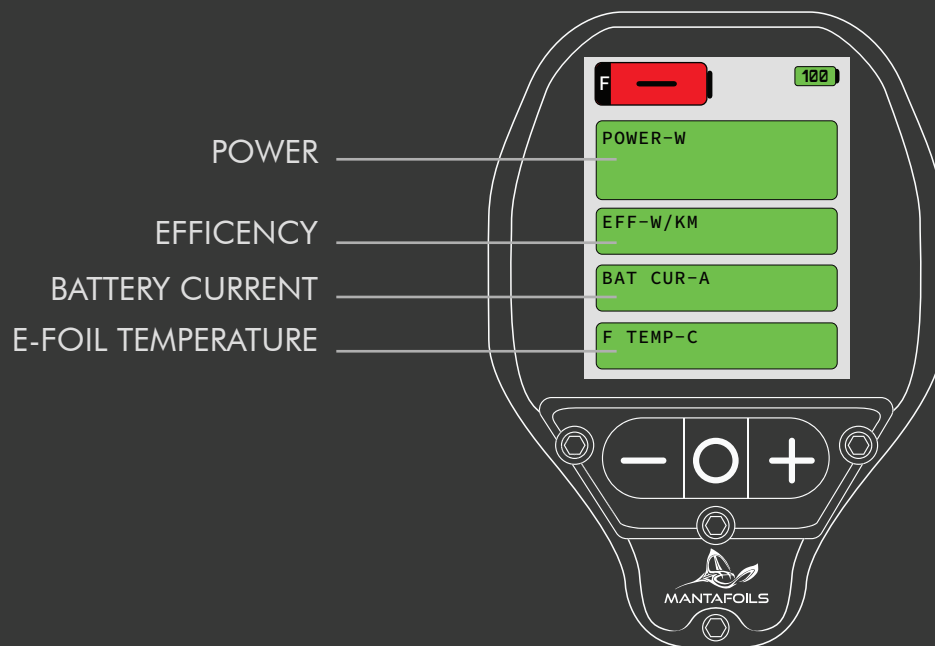



Hold the '-' and '+' together for 3 seconds to enter the settings menu and to exit hold the '-' button for 3 seconds or until you arrive on the homescreen page.

In the menu:

1. The first page is used for pairing the remote with the efoil board.

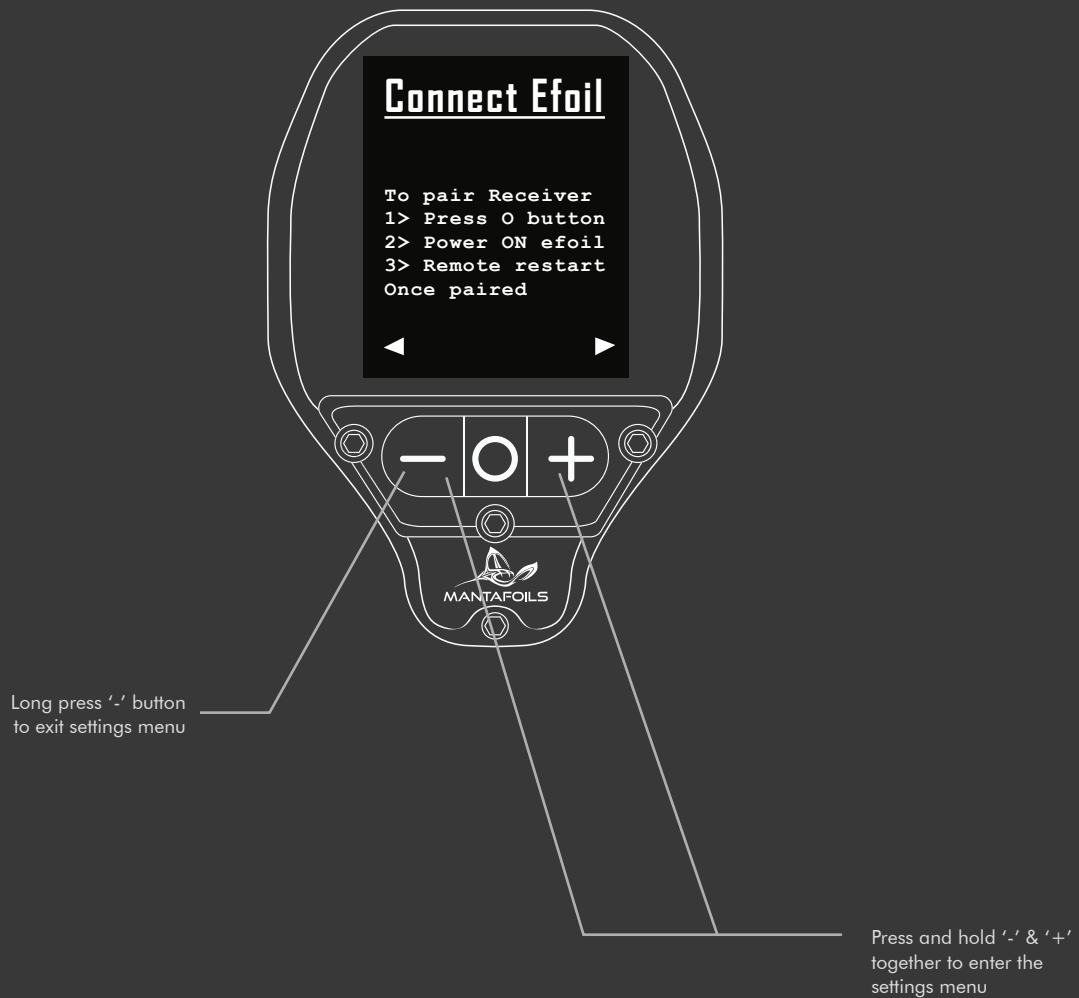



To connect your remote to the E-foil follow the instructions as shown on the screen.

- Press the 'O' button to enter into pairing mode. This will take you to the screen shown below:

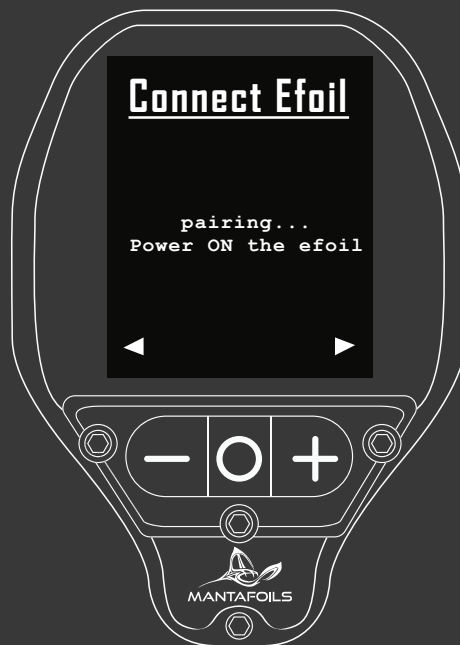

- When on this page, close down the lid of your board to power on the E-foil.
- Your remote will power off indicating the remote is paired.



- Restart the remote by long pressing the 'O' button. When the remote restarts, you should read 'LOCKED' on the home screen page. On pairing, the GPS is also activated.

The bars indicate signal strength between the remote and the receiver.

E-foil battery charge should appear, turning green.

The safety lock feature will be activated when receiver is paired

Long press the '+' button to reset the ride.

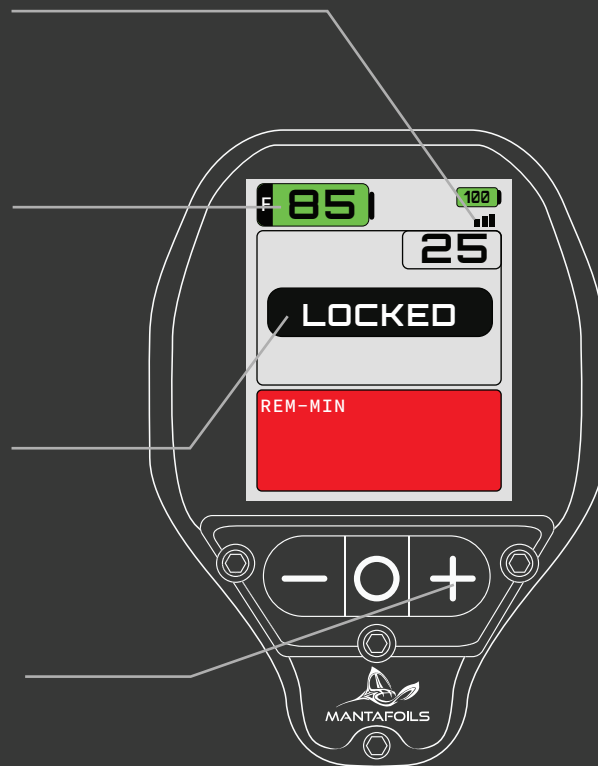



From the settings page, navigate to the trigger calibration page by pressing the '+' button.

- On this page, Release the throttle and press the 'O' button on the screen to begin sensor calibration.



1. On this page, ensure the trigger is not pressed

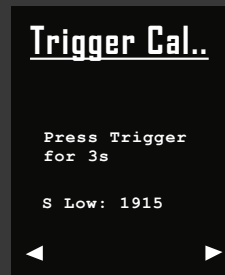

2. Press and hold the trigger for 3 seconds or until the screen changes.



3. When you see this screen. Release the trigger completely.



4. Your trigger calibration has completed.



5. Test the calibration of your trigger on this screen.

Once completed, Pressing any button on the remote will restart the remote indicating that the changes have been saved.



From the settings page, navigate to the power limit page by pressing the '+' button.

- Press the 'O' button to set the power limit to the desired value. The values change in increments of 10.
- Once set, navigate to a different page by using '-' or '+' buttons and navigate back to the same page to ensure that the desired value is saved.

Note:

This feature is designed to make the ride easily controlable for amateur and young riders.

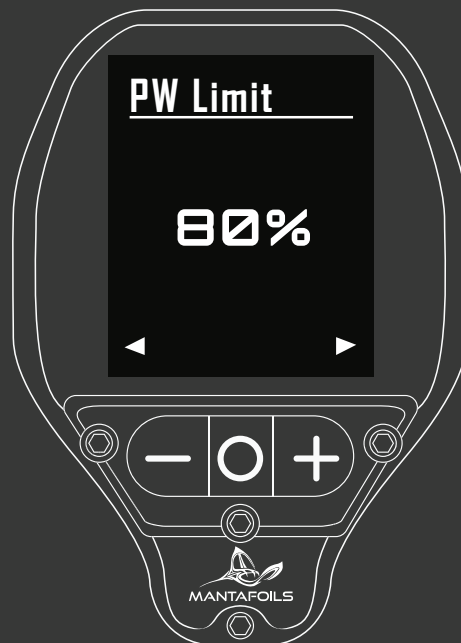



From the settings page, navigate to the units page by pressing the '+' button.

- The available Units are:
 1. The SI units : kilometer/hour
 2. The US units : miles/ hour
 3. The nautical units: knots/hour

Keep pressing the 'O' button on this page to change the units on your remote. Press the '-' or '+' to navigate to other settings menu. The changes are saved automatically.





From the settings page, navigate to the metrics page by pressing the '+' button.

- Metrics setting gives you numerous options to personalize the remote display interface and colors.

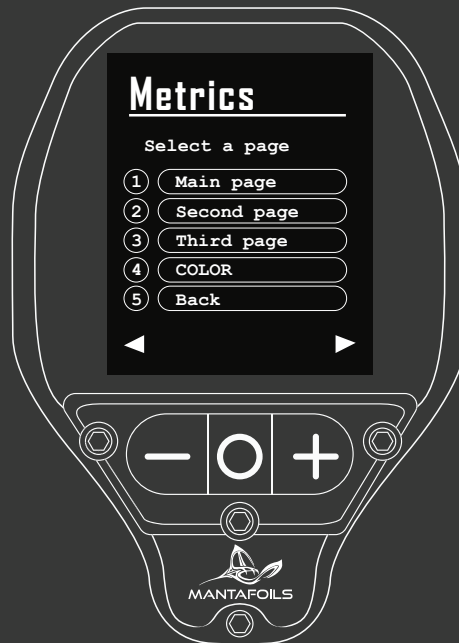



Navigating the Metrics menu

- It is important to understand the navigation controls in the metrics settings



- On this page, press the 'O' button to select options
- Use the '-' and '+' buttons to scroll through the page options
- Press the 'O' button to enter the selected page settings

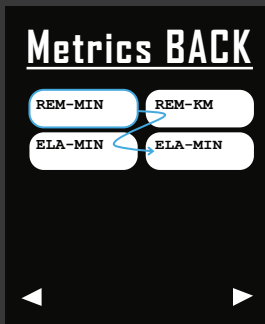

- On this page, use the '+' button to navigate forward through the options.
- Use the '-' button to navigate backward through the options.

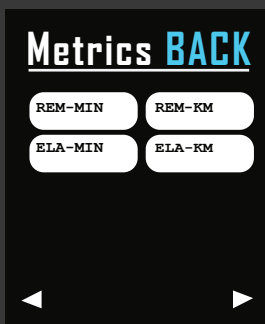

- To go back to the previous menu, keep pressing '-' button to navigate back until 'BACK' is selected.
- Once selected, press the 'O' button to go back to the previous menu



Customizing the Display Cells

- Each page setting shows the cells available on that screen.
- You can choose what information is displayed in each individual cell or you can choose to leave it empty.
- The Main page can hold a maximum of 4 cells. The Second and Third page can hold a maximum of 10 cells each.

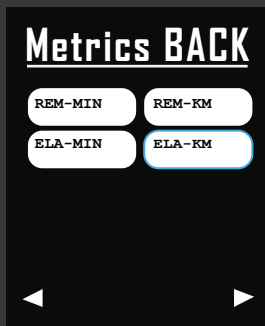

- On this page, navigate to your desired cell.
- Press 'O' button to scroll through the options.
- Once your desired option is selected, navigate away using the '-' and '+' buttons, your selection will be saved automatically.

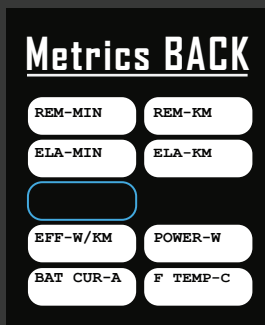

- To remove a cell completely, keep pressing the 'O' button until the slot is empty.
- Likewise, to fill in an empty slot, navigate to it, scroll through the options and select your desired option.
- A minimum of one cell must remain occupied.

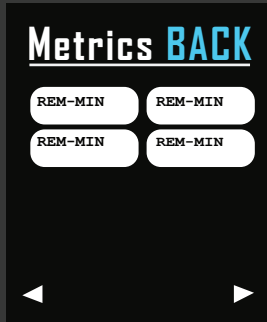

- To go back to the previous menu, keep pressing '-' button to navigate back until 'BACK' is selected.
- Once selected, press the 'O' button to go back to the previous menu

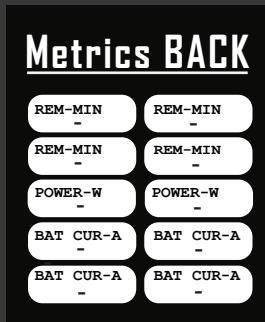

- If all the cells on a page are left empty, the page will be omitted from being displayed.
- if an even number of cells consecutively contain the same data, it will regroup as one single cell.
- For regrouping, the minimum must be of two cells and a maximum of four cells.

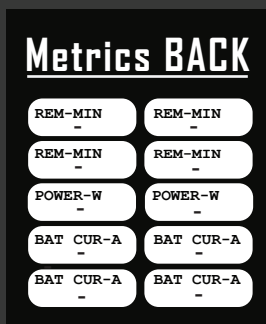

The settings from the metrics page

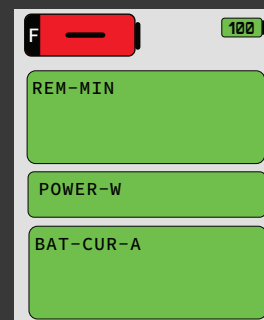

The display output



Changing the display colors

- Scroll down to the fourth option. By default it is set to 'color'

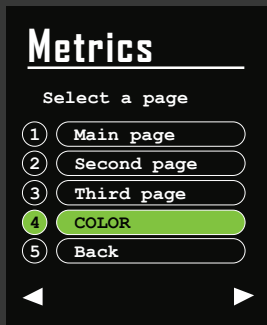

- Press the 'O' button to scroll through the colors
- You can choose between three options:
 - COLOR
 - BLACK
 - WHITE

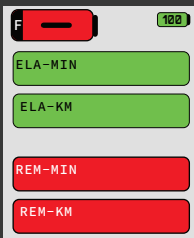

COLOR

- This option displays the cells in different colors.
- Depending on the cell values, the colors change between Green, Yellow and Red.

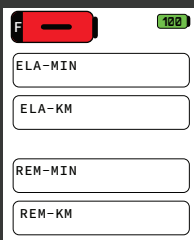

WHITE

- This option displays all the cells in white color.

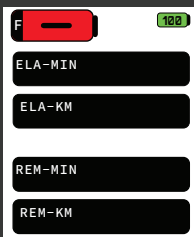

BLACK

- This option displays all the cells in black color.



From the settings page, navigate to the throttle start page by pressing the '+' button.

- Throttle start is the power of the foil when the trigger is pressed at the startup.
- This feature is included to avoid unexpected power bursts when starting the ride.
- Press the 'O' button to set the throttle start to the desired value. The values change in increments of 5.

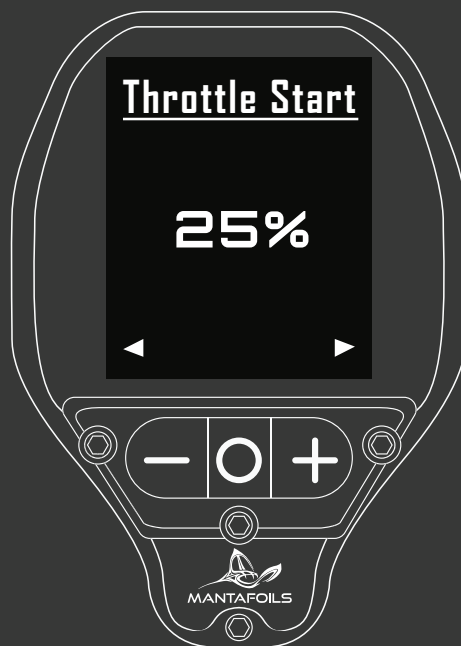



From the settings page, navigate to the throttle ramp page by pressing the '+' button.

- Throttle ramp is sensitivity of the acceleration of the foil.
- This value controls how quickly the power output ramps up or down between different power levels.
- On this page, press the 'O' button to scroll through the options.
- Once set, navigate to a different page by using '-' or '+' buttons and navigate back to the same page to ensure that the desired value is saved





From the settings page, navigate to the firmware update page by pressing the '+' button.

- Make sure the remote is paired to your efoil. (For this, read the instructions on pairing your remote with the board)



Click on the Remote Control Icon



Click on the latest firmware version

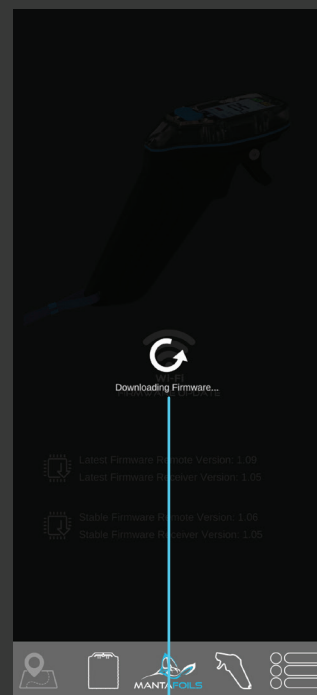

Wait for the download to finish



After the firmware update is downloaded on your mobile application, navigate to the firmware update page by pressing the '+' button seven times from the sub menu page.

- Press the 'O' button on the remote to activate the MantaFoil wifi network.
- Your remote will read 'Foil connected' and you will be prompted to connect your phone
- Connect your phone to the MantaFoil wifi network.
- Click on the 'UPDATE' button on the application to install the update.

Wifi username: MANTAFOIL

Wifi password: Manta135

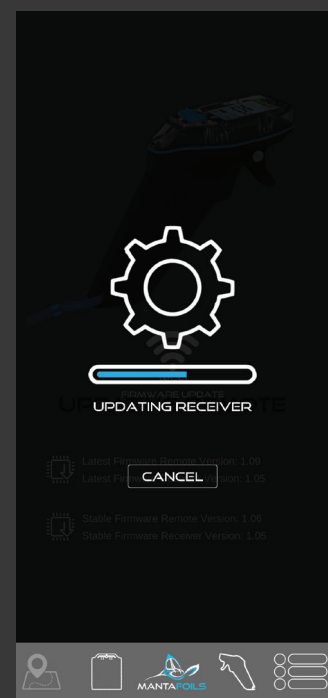
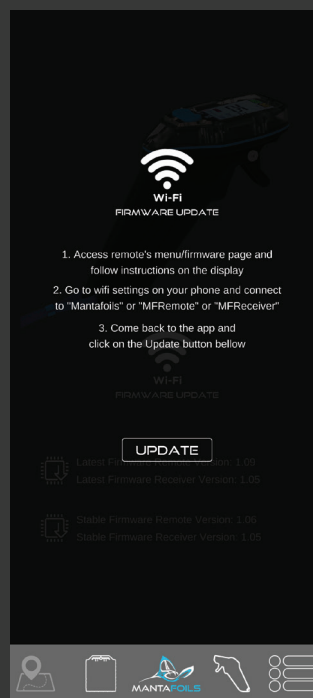
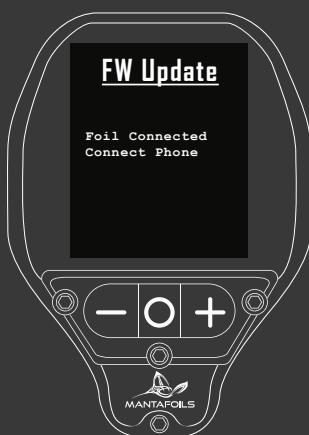

Once the installation is complete, your remote will read 'Lost Connection' and will automatically restart. This indicates that the update is successfully completed.

You can also verify the update by checking the Firmware Version shown on the start up page when the remote is powered on



From the settings page, navigate to the reset system page by pressing the '+' button.

- Press the 'O' button on the remote to reset the system.
- Your remote will automatically restart after the resetting is done.





From the settings page, navigate to the logs access page by pressing the '+' button.

- Press the 'O' button to toggle the system On and Off.
- All travel logs are recorded by default.
- Setting it to 'ON' will activate transfer the logs data to the application.
- Setting it to 'OFF' will deactivate the transfer of logs data to the





Once the logs access is enabled, open the Mantafoils application and click on the ride logs icon.

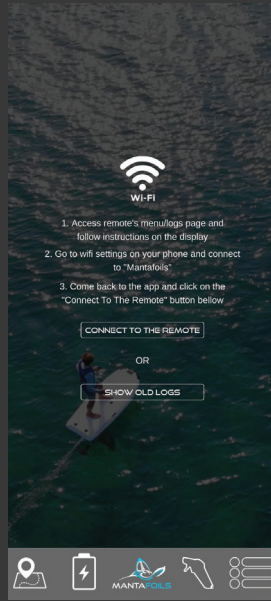

Connect to the Mantafoils wifi network and click 'connect to remote'. To view your ride logs click 'show old logs'

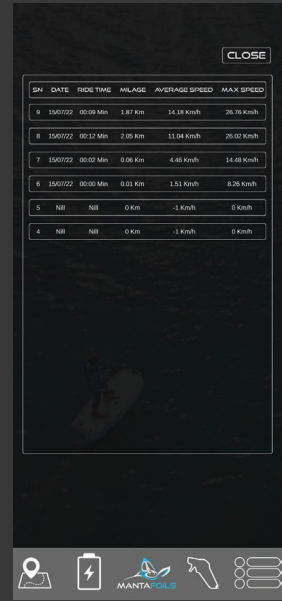

All the ride logs will appear listed. Click on any of the log files to view details of the ride.

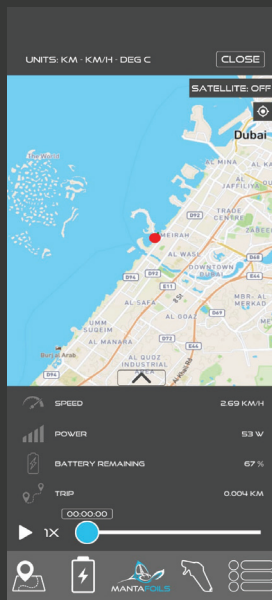

Once the logs access is enabled, open the Mantafoils application and click on the ride logs icon to replay your ride.

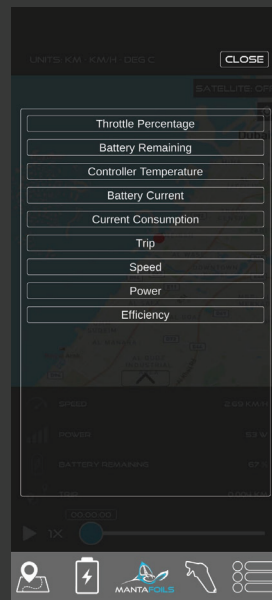

Clicking on any of the data presented will open an expanded window view of all the available ride information



The MantaFoil remote is charged wirelessly. The wireless charger and cable are provided in your Efoil Kit.

- To charge the remote, plug in the wireless charger.
- Place the remote on the wireless charging pad.
- The blue light on the remote and the pad indicate charging in progress.
- The blue light on the remote will turn off once it is fully charged.
- The remote charge must be at least 20% to be able to use for riding.

Charge time : 2 hours (when less than 10%)

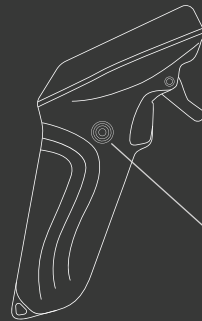

Keep this side towards the wireless charging pad.

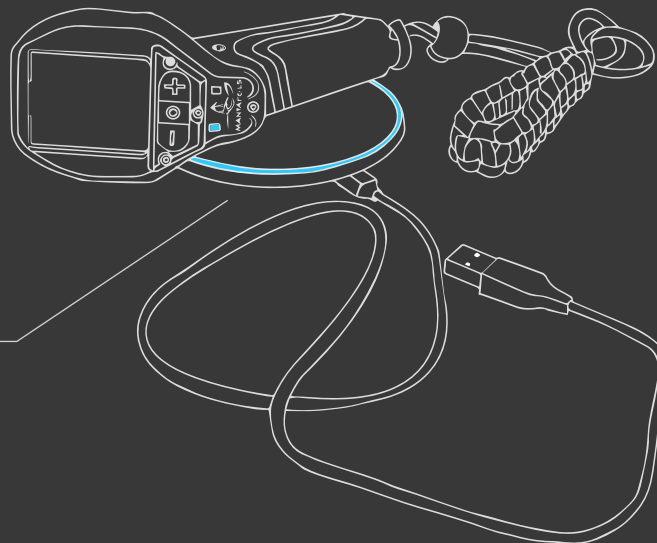

Place the remote roughly at a 45 degree angle from the charging cable on the pad as shown in the picture



To hardware reset your remote, place a magnet on the side of the bottom right corner of the remote screen. The remote will power off. You can then restart your remote. This feature is useful in the unlikely event of a software hang or frozen screen.





| Common Issues | Suggested Solution |
|--|--|
| Remote not Pairing | <ul style="list-style-type: none">- Your E-foil may not be powered on. Check Battery Status (Refer to E-foil user manual) and retry.- Ensure the data cable connectors are connected securely and no water has entered in. If you notice traces of water, leave cables out for drying and retry.- Ensure the lid of your board is closed properly. |
| Remote Screen is stuck | <ul style="list-style-type: none">- Hardware reset your remote. |
| Remote does not turn ON | <ul style="list-style-type: none">- Ensure your remote is charged and re-try |
| Cannot connect to Mantafoil wifi for firmware update | <ul style="list-style-type: none">- Read the firmware update section of the user manual. Follow instructions and try again. |
| Remote not Charging | <ul style="list-style-type: none">- Ensure the instructions in the user manual section remote charging are followed. |
| Remote Firmware not updating | <ul style="list-style-type: none">- Contact Mantafoil Support team. |
| Water inside Remote | <ul style="list-style-type: none">- In the unlikely event of water inside the remote, discontinue use of the remote and contact Mantafoil Support team. |

If any issues persist with your remote, contact mantafoils support team at sales@mantafoils.com



— MANTAFOILS —

INFLATABLE

EFOIL - SLIDE FOIL

MANTAFOILS FZ LLC
PBU C49 - Dubai Production City
www.mantafoils.com

for further questions or queries contact :
sales@mantafoils.com
support@mantafoils.com